CELLTHERM

The Know-how Team

Smart Product Solutions all around Coldrooms

Headquarters CELLTHERM Gronau

CELLTHERM Isolierung GmbH
Am Buddenbrook 78
D-48599 Gronau

Phone: +49 25 65 – 70 5-0
Fax: +49 25 65 – 70 564
e-mail: info@celltherm.de

Subsidiary CELLTHERM UK

CELLTHERM Coldrooms Ltd.
Unit 4, Acan Way
Narborough
Leicester
LE19 2GW
Phone: +44 116 – 275 1331
Fax: +44 116 – 275 1304
e-mail: sales@celltherm.co.uk

Contact Persons at the Gronau Plant

		Phone	Fax
Management:	Holger Bialdiga h.bialdiga@celltherm.de	+49 2565-705-11	+49 2565-705-64
	Bart Verhoeven b.verhoeven@celltherm.de	+49 2565-705-10	+49 2565-705-64
Export:	Holger Bialdiga	+49 2565-705-11	+49 2565-705-64
Technology:	Bart Verhoeven	+49 2565-705-10	+49 2565-705-64
Quotation processing:	Andreas Reining vertrieb@celltherm.de	+49 2565-705-14	+49 2565-705-64
	Michael Teichmann vertrieb@celltherm.de	+49 2565-705-35	+49 2565-705-64
Order processing:	Gaby Vennekötter vertrieb@celltherm.de	+49 2565-705-16	+49 2565-705-64
Dispatch:	Marion Baring m.baring@celltherm.de	+49 2565-705-25	+49 2565-705-60
Shipping:	Marion Baring m.baring@celltherm.de	+49 2565-705-25	+49 2565-705-60

Contents

Register	Description	Page
1	<u>Technical documentations</u>	
	1.1 General Product Description	1 - 2
	- Insulation	
	- Cladding	
	- Wall design	
	- Floors	
	- Doors	
	1.2 Spacing	3 - 6
	- Graphical Overview	
	- Table Format	
	1.3 Guidelines for using Coldrooms	1 - 4
	- Wall Distances/environmental Conditions	
	- Claddings	
	- Cleaning Rules	
	1.4 Assembly Instructions	1 - 6
	- Panel Coding	
	- General Installation Instructions	
2	<u>Walk-in Chiller PUR 80 mm</u>	1 - 2
3	<u>Walk-in Freezer PUR 80 mm</u>	1 - 2
4	<u>Walk-in Freezer PUR 100 mm</u>	1 - 2
5	<u>Walk-in Freezer PUR 120 mm</u>	1 - 2
6	<u>Walk-in Freezer PUR 150 mm</u>	1 - 2
7	<u>Doors</u>	
	7.1. Single leaf hinged Doors in Panel Frames	1
	7.2. Single leaf hinged Doors for Installation in Brick Walls	2
	7.3. Double leaf hinged Doors for Installation in Brick Walls	3
	7.4. Hatches	4
	7.5. Sliding Doors for walk-in Chillers	5
	7.6. Sliding Doors for walk-in Freezers	6
	7.7. Glass Doors	7
	7.8. Sectional Doors / Rolling Doors / Swing Doors	8

Register	Description	Page
8	<u>Accessories / optional Features</u>	
	- Partition walls	1
	- Mounting Profiles	1
	- Lighting	1
	- Thermometer	1
	- Crash Barrier	1
	- Floor Drain	1
	- Ceiling Carriers	2
	- Access Ramps	3
	- Strip Curtains	3
9	<u>Refrigeration Units</u>	
9.1.	CELLBOX wall-mount units Propane	1 - 8
9.2.	CELLBOX roof-mount units Propane	1 - 7
9.3.	CELLBOX wall-mount units R452a	1 - 9
9.4.	CELLBOX roof-mount units R452a	1 - 7
9.5.	CELLBOX split units R452a	1 - 8
10	<u>Shelving Systems</u>	1 - 2
	- Aluminium, standard Systems	
	- Stainless Steel	
11	<u>General Terms and Conditions of Sale, Delivery and terms of payment</u>	

General Product Description

Coldroom panels of modular design, free of thermal bridges, robust, and accurate to size.

Insulation: Water-based rigid PUR-system, foamed entirely without CFC, halogenated CFC, and fluorocarbon, in accordance with the EU Halon Guidelines dated 01. 01. 2003. Insulation density 40 – 45kg/m³

Wall thickness 80 mm: recommended temperature range up to +2°C, for temperature differences up to $\Delta T = 40$ K in accordance with DIN 2055

Wall thickness 100 mm: recommended temperature range up to -20°C, for temperature differences up to $\Delta T = 50$ K in accordance with DIN 2055

Wall thickness 120mm: recommended temperature range up to -30°C, for temperature differences up to $\Delta T = 55$ K in accordance with DIN 2055

Wall thickness 150mm: recommended temperature range up to -45°C, for temperature differences up to $\Delta T = 70$ K in accordance with DIN 2055

Cladding: The CELLTHERM standard coldroom consists of the following interior and exterior cladding:

- Prime galvanized sheet steel with a white zinc-aluminum-coating, baked-on enamel
- Colour: RAL 9002
- Thickness: 0,63mm
- In addition, all panels are covered by protective foil for transport and assembly. Foil to be removed after assembly.

Additional finishes are available upon request!

Wall design: All panels are easily assembled thanks to a unique male and female profiling which ensures accurate panel line-up and prevents incorrect mounting.

Cam-locks within the panels give a fast build-up and guarantee a tight, efficient joint preventing ingress and moisture.

Floors: The following floor panels are available for interior cladding:

Plastic coated GFK

Anti-slip, reinforced plastic coated surface on waterproof hexagonal birch plywood.

max. permissible load per rubber wheel:	200 kg
Load bearing surface:	4 cm ²
max. permissible surface load:	30.000 N
Anti-slip property:	R11

Stainless steel (1.4301) pattern rolled or ground

Material thickness 0.8 / 1.5 mm, waterproof birch plywood directly foamed and covered by stainless steel.

max. permissible load per rubber wheel:	200 / 300 kg
Load bearing surface:	4 cm ²
max. permissible surface load:	20.000 / 30.000 N
Anti-slip property:	R11 / R12 (no extra charge)

Stainless steel (1.4301) floor pan or plate hot rolled - Material thickness 3.0 mm

Floor Pan entirely glued to a waterproof birch plywood. After coldroom assembly, a pan consisting of hot rolled stainless steel which exhibits edges drawn up to a height of 30 mm and welded in the corners is entirely glued to the multiplex plate. Z-profile borders the floor / wall. Reinforced in the area of the seam and firmly attached in a waterproof manner by means of counter-sunk cup blind rivets.

Floor Plate same as Pan without drawn up edges and Z-profile.

max. permissible load per rubber wheel:	400 kg
Load bearing surface:	4 cm ²
max. permissible surface load:	40.000 N
Anti-slip property (optional):	R11 / R12

Doors: Single leaf hinged doors which can be opened to the outside, supported with a replaceable door gasket resistant to fats and acids and adjustable rising butt hinges. Press lever or Jumbo handle, lockable, emergency opener on the inside. Doors can be optionally hinged left or right.

Cladding: Doors in the deep-freeze area exhibit a door frame heater and a heated pressure relief valve. Threshold of stainless steel, door and door frame profiles extruded from a special plastic, highly resistant to impact and suitable for temperatures down to -65°C.

Additional claddings are available upon request!

Aeration Rings For freezers, we generally recommend underfloor aeration rings (210 mm in diameter, optionally 40, 30 or 20 mm in height). The distance between two rings shall not exceed 600 mm. In cases of higher wheel loads, the distance between the rings should be reduced to 300 mm.

CELLTHERM- modules of only 175 mm Spacing in Length and Width

Standard heights:	165 cm	180 cm	195 cm	210 cm	225 cm
(interior)	240 cm	255 cm	270 cm	300 cm	330 cm

To determine the exterior height, the thickness of the respective insulation—and in cases of freezers an additional 40 mm for the underfloor aeration rings—are to be added.

3D Format – Exterior Dimensions (Example for Insulation Thickness 80 mm)

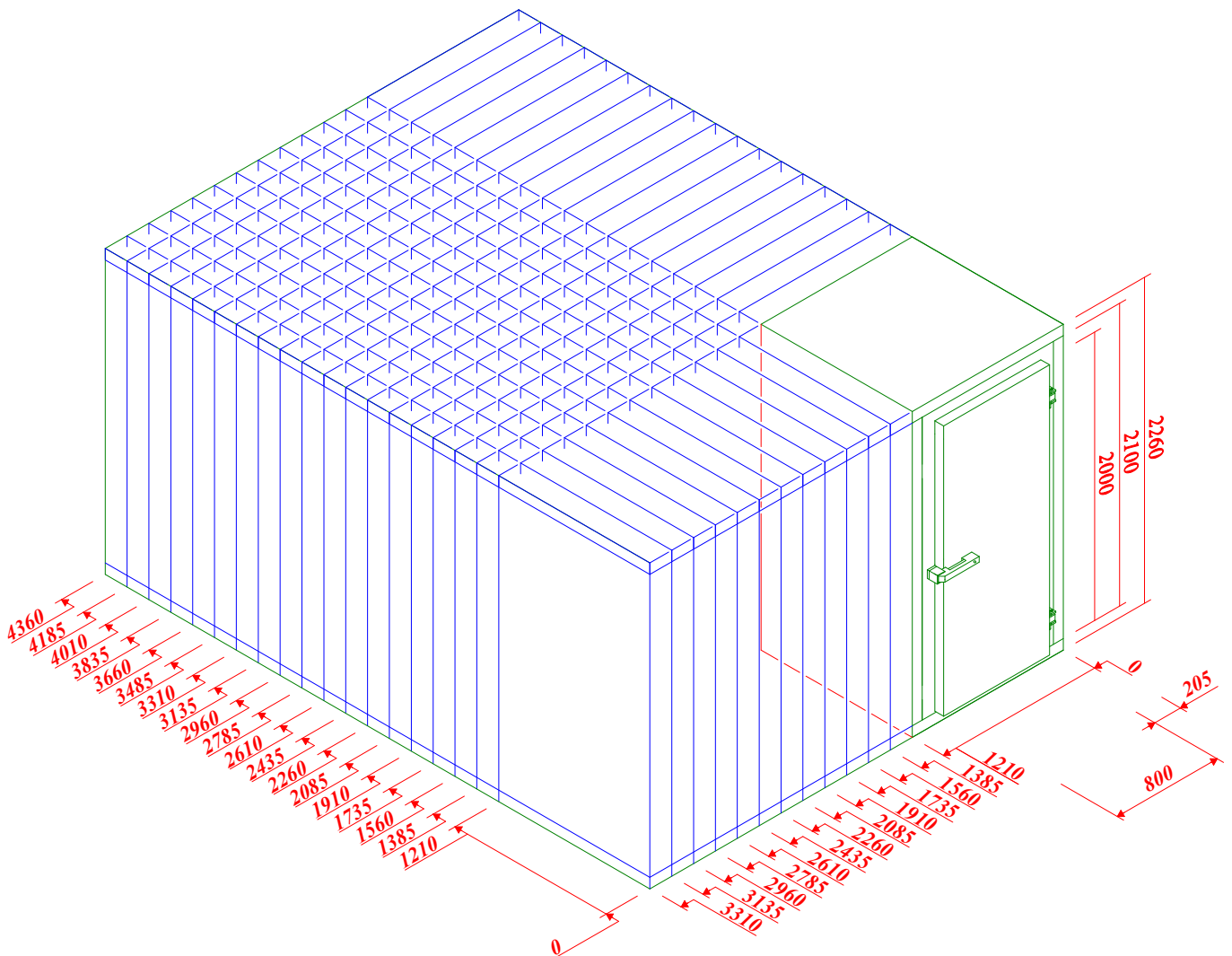

Table Overview

Insulation 80 mm		Insulation 100 mm		Insulation 120 mm		Insulation 150 mm	
Exterior	Interior	Exterior	Interior	Exterior	Interior	Exterior	Interior
1,210	1,050	1,250	1,050	1,290	1,050	1,640	1,340
1,385	1,225	1,425	1,225	1,465	1,225	1,815	1,515
1,560	1,400	1,600	1,400	1,640	1,400	1,990	1,690
1,735	1,575	1,775	1,575	1,815	1,575	2,165	1,865
1,910	1,750	1,950	1,750	1,990	1,750	2,340	2,040
2,085	1,925	2,125	1,925	2,165	1,925	2,515	2,215
2,260	2,100	2,300	2,100	2,340	2,100	2,690	2,390
2,435	2,275	2,475	2,275	2,515	2,275	2,865	2,565
2,610	2,450	2,650	2,450	2,690	2,450	3,040	2,740
2,785	2,625	2,825	2,625	2,865	2,625	3,215	2,915
2,960	2,800	3,000	2,800	3,040	2,800	3,390	3,090
3,135	2,975	3,175	2,975	3,215	2,975	3,565	3,265
3,310	3,150	3,350	3,150	3,390	3,150	3,740	3,440
3,485	3,325	3,525	3,325	3,565	3,325	3,915	3,615
3,660	3,500	3,700	3,500	3,740	3,500	4,090	3,790
3,835	3,675	3,875	3,675	3,915	3,675	4,265	3,965
4,010	3,850	4,050	3,850	4,090	3,850	4,440	4,140
4,185	4,025	4,225	4,025	4,265	4,025	4,615	4,315
4,360	4,200	4,400	4,200	4,440	4,200	4,790	4,490
4,535	4,375	4,575	4,375	4,615	4,375	4,965	4,665
4,710	4,550	4,750	4,550	4,790	4,550	5,140	4,840
4,885	4,725	4,925	4,725	4,965	4,725	5,315	5,015
5,060	4,900	5,100	4,900	5,140	4,900	5,490	5,190
5,235	5,075	5,275	5,075	5,315	5,075	5,665	5,365
5,410	5,250	5,450	5,250	5,490	5,250	5,840	5,540
5,585	5,425	5,625	5,425	5,665	5,425	6,015	5,715
5,760	5,600	5,800	5,600	5,840	5,600	6,190	5,890
5,935	5,775	5,975	5,775	6,015	5,775	6,365	6,065
6,110	5,950	6,150	5,950	6,190	5,950	6,540	6,240
6,285	6,125	6,325	6,125	6,365	6,125	6,715	6,415

Insulation 80 mm		Insulation 100 mm		Insulation 120 mm		Insulation 150 mm	
Exterior	Interior	Exterior	Interior	Exterior	Interior	Exterior	Interior
6,460	6,300	6,500	6,300	6,540	6,300	6,890	6,590
6,635	6,475	6,675	6,475	6,715	6,475	7,065	6,765
6,810	6,650	6,850	6,650	6,890	6,650	7,240	6,940
6,985	6,825	7,025	6,825	7,065	6,825	7,415	7,115
7,160	7,000	7,200	7,000	7,240	7,000	7,590	7,290
7,335	7,175	7,375	7,175	7,415	7,175	7,765	7,465
7,510	7,350	7,550	7,350	7,590	7,350	7,940	7,640
7,685	7,525	7,725	7,525	7,765	7,525	8,115	7,815
7,860	7,700	7,900	7,700	7,940	7,700	8,290	7,990
8,035	7,875	8,075	7,875	8,115	7,875	8,465	8,165
8,210	8,050	8,250	8,050	8,290	8,050	8,640	8,340
8,385	8,225	8,425	8,225	8,465	8,225	8,815	8,515
8,560	8,400	8,600	8,400	8,640	8,400	8,990	8,690
8,735	8,575	8,775	8,575	8,815	8,575	9,165	8,865
8,910	8,750	8,950	8,750	8,990	8,750	9,340	9,040
9,085	8,925	9,125	8,925	9,165	8,925	9,515	9,215
9,260	9,100	9,300	9,100	9,340	9,100	9,690	9,390
9,435	9,275	9,475	9,275	9,515	9,275	9,865	9,565
9,610	9,450	9,650	9,450	9,690	9,450	10,040	9,740
9,785	9,625	9,825	9,625	9,865	9,625	10,215	9,915
9,960	9,800	10,000	9,800	10,040	9,800	10,390	10,090
10,135	9,975	10,175	9,975	10,215	9,975	10,565	10,265
10,310	10,150	10,350	10,150	10,390	10,150	10,740	10,440
10,485	10,325	10,525	10,325	10,565	10,325	10,915	10,615
10,660	10,500	10,700	10,500	10,740	10,500	11,090	10,790
10,835	10,675	10,875	10,675	10,915	10,675	11,265	10,965
11,010	10,850	11,050	10,850	11,090	10,850	11,440	11,140
11,185	11,025	11,225	11,025	11,265	11,025	11,615	11,315
11,360	11,200	11,400	11,200	11,440	11,200	11,790	11,490
11,535	11,375	11,575	11,375	11,615	11,375	11,965	11,665
11,710	11,550	11,750	11,550	11,790	11,550	12,140	11,840

Insulation 80 mm		Insulation 100 mm		Insulation 120 mm		Insulation 150 mm	
Exterior	Interior	Exterior	Interior	Exterior	Interior	Exterior	Interior
11,885	11,725	11,925	11,725	11,965	11,725	12,315	12,015
12,060	11,900	12,100	11,900	12,140	11,900	12,490	12,190
12,235	12,075	12,275	12,075	12,315	12,075	12,665	12,365
12,410	12,250	12,450	12,250	12,490	12,250	12,840	12,540
12,585	12,425	12,625	12,425	12,665	12,425	13,015	12,715
12,760	12,600	12,800	12,600	12,840	12,600	13,190	12,890
12,935	12,775	12,975	12,775	13,015	12,775	13,365	13,065
13,110	12,950	13,150	12,950	13,190	12,950	13,540	13,240
13,285	13,125	13,325	13,125	13,365	13,125	13,715	13,415
13,460	13,300	13,500	13,300	13,540	13,300	13,890	13,590
13,635	13,475	13,675	13,475	13,715	13,475	14,065	13,765
13,810	13,650	13,850	13,650	13,890	13,650	14,240	13,940
13,985	13,825	14,025	13,825	14,065	13,825	14,415	14,115
14,160	14,000	14,200	14,000	14,240	14,000	14,590	14,290
14,335	14,175	14,375	14,175	14,415	14,175	14,765	14,465
14,510	14,350	14,550	14,350	14,590	14,350	14,940	14,640
14,685	14,525	14,725	14,525	14,765	14,525	15,115	14,815
14,860	14,700	14,900	14,700	14,940	14,700	15,290	14,990
15,035	14,875	15,075	14,875	15,115	14,875	15,465	15,165
15,210	15,050	15,250	15,050	15,290	15,050	15,640	15,340
15,385	15,225	15,425	15,225	15,465	15,225	15,815	15,515
15,560	15,400	15,600	15,400	15,640	15,400	15,990	15,690
15,735	15,575	15,775	15,575	15,815	15,575	16,165	15,865
15,910	15,750	15,950	15,750	15,990	15,750	16,340	16,040
16,085	15,925	16,125	15,925	16,165	15,925	16,515	16,215
16,260	16,100	16,300	16,100	16,340	16,100	16,690	16,390
16,435	16,275	16,475	16,275	16,515	16,275	16,865	16,565
16,610	16,450	16,650	16,450	16,690	16,450	17,040	16,740
16,785	16,625	16,825	16,625	16,865	16,625	17,215	16,915
.....		

Specific dimensions upon request

Guidelines for Using CELLTHERM Coldrooms

Temperature Ranges

Due to the tight joint of the panels, coldrooms manufactured by CELLTHERM prevent the diffusion of steam and exhibit both exceptional static characteristics and an excellent level of insulation.

Depending upon the application, we recommend the following insulation thicknesses:

Wall thickness 80 mm: recommended temperature range up to +2°C,
for temperature differences up to $\Delta T = 40$ K in accordance with DIN 2055

Wall thickness 100 mm: recommended temperature range up to -20°C,
for temperature differences up to $\Delta T = 50$ K in accordance with DIN 2055

Wall thickness 120mm: recommended temperature range up to -30°C,
for temperature differences up to $\Delta T = 55$ K in accordance with DIN 2055

Wall thickness 150mm: recommended temperature range up to -45°C,
for temperature differences up to $\Delta T = 70$ K in accordance with DIN 2055

In cases of higher temperature differences, we recommend a coldroom design with multiple layers.

Installation Site

Please make sure that the floor panels are always arranged on a horizontal, smooth, and statically suitable surface. If the coldroom will exhibit temperatures below the freezing point, it requires a pressure relief valve as well as a door frame heater and aeration beams. The gap between the floor panels and the solid ground must structurally facilitate ventilation. This minimizes the possibility for the formation of condensed water underneath the floor panels.

An electrical heater mat underneath the panels to prevent freezing can be arranged as an alternative.

Floor

With regard to the structure, the floor of the building must fulfill a number of minimum requirements to ensure the smooth installation of the coldroom.

As every bump in the ground will impact the floor of the coldroom, it must be compensated prior to arranging the floor panels. The floor of the building must form a horizontal plane. Bumps up to 10 mm are acceptable (and will be compensated during assembly).

Bumps in excess of 10 mm must be structurally compensated prior to assembling the coldroom.

If you use aeration rings, smaller bumps can be compensated. To that end, suitable material (e.g. tiles) is placed underneath the rings. Please make sure that this material is prevented from shifting.

Wall Distances / Air Circulation

If the coldroom is installed in existing rooms or at adjacent walls, a wall distance of at least 50 mm between the coldroom and the wall is required to ensure sufficient air circulation at the exterior wall of the coldroom. This reduces the possibility of the formation of condensed water.

Doors

With regard to the doors, please ensure that their design corresponds to their intended use.

A door frame heater is absolutely necessary for coldrooms exhibiting a coldroom temperature below 0°C. The same applies for coldrooms which are installed in outdoor areas potentially exhibiting a surrounding temperature below 0°C.

In cases of lowered coldrooms, use a floor level door design. The same applies to coldrooms without floors attached in U profiles.

Roofing (Outdoor Installation)

If a coldroom is installed outdoors or in an area allowing full exposure to climatic influences, the coldroom requires both roofing as well as a permanently elastic seal of the outer panel seams.

The roof should protect the coldroom from water, snow, and wind exposure and must exhibit an appropriate size, in particular in the area of the door.

In addition, if it is reasonable to assume that the surrounding temperature can fall below 0°C, doors must generally be equipped with a door frame heater.

Surface Materials

Various materials are available for the exterior and interior surfaces of CELLTHERM coldrooms. These can also be applied in a combined manner.

The essential guidelines for selecting surface materials are:

Intended use	: Climatic conditions, chemical exposure, physical exposure
Customer requirement	: colour; chemical, biological, and physical requirements
Cleaning exposure	: Use of cleaning devices facilitating high pressure and steam, chemical exposure to cleaning agents and disinfectants

The following materials are available as interior and exterior cladding for coldrooms:

- Prime galvanized sheet steel with a white zinc-aluminum-coating, baked-on enamel (RAL 9002)
- Sheet V2A material number 1.4301-AISI 304 in various surface structures
- Sheet V4A material number 1.4401-AISI 316 in various surface structures
- Sheet aluminium in various surface structures

The following claddings are available for coldroom floors:

- Prime galvanized sheet steel with a white zinc-aluminum-coating, baked-on enamel (RAL 9002)
- Sheet V2A material number 1.4301-AISI 304 in various surface structures
- Sheet V4A material number 1.4401-AISI 316 in various surface structures
- Sheet aluminium in various surface structures
- Anti-slip, reinforced plastic coated cladding (GFK)

Durability of the Claddings

Damage to the cladding (e.g. scratches, cracks, and deformations) causes flaking and/or corrosion unless it is immediately repaired.

Cleaning Rules

Coated, baked-on enamel RAL 9002	<ul style="list-style-type: none">- Wash with warm water- Addition of slightly alkaline cleaning agents is permissible (without abrasive, pH value 6-10)- Do not use high pressure cleaning devices
Aluminium	<ul style="list-style-type: none">- Wash with warm water- Addition of slightly alkaline cleaning agents is permissible (without abrasive, pH value 6-10)- Do not use high pressure cleaning devices
V2A / V4A	<ul style="list-style-type: none">- Clean with warm or hot water or steam- Addition of alkaline cleaning agents is permissible- Use of cleaning devices facilitating high pressure and steam is to some extent permissible
Plastic coated cladding (GFK)	<ul style="list-style-type: none">- Wash with warm water- Addition of slightly alkaline cleaning agents is permissible (without abrasive, pH value 6-10)- Do not use high pressure cleaning devices

After cleaning, we recommend that the room be thoroughly dried prior to the initial operation.

Disinfection

To disinfect the coldrooms, only use disinfectants that do not attack or discolour the surface materials or cause other changes (maceration or flaking of finishes).

After the disinfection with an appropriate disinfectant has been completed, the surfaces must be once again neutralized unless they are already neutral.

Information with regard to the suitability of a disinfectant is included in the safety data sheet or similar information material of the respective disinfectant manufacturer.

Assembly of CELLTHERM Coldrooms

Coldrooms by CELLTHERM consist of frameless, self-supporting modular panels. All panel edges consist of male and female foam profiling, stepped at halfway and can even be assembled in a mirror-inverted manner, preventing incorrect mounting and guaranteeing accurate panel line-up. The foam-to-foam camlocked panels assure tight joining and structural strength preventing ingress of moisture. In addition, the integrated cam locks enable a fast assembly of the coldroom.

As assembly errors can only be rectified by means of lengthy procedures, please make sure that you strictly observe the following instructions. The instructions apply to all insulation thicknesses.

Preparation

Please verify by means of the included coldroom diagram that all components have been delivered. Each individual panel is numbered by the manufacturer in accordance with the following code:

Identification	Meaning
W	= Wall panel
WE	= Wall-corner panel
WEE	= Wall-corner-corner panel
WO	= Wall panel for cell without floor
BK	= Floor panel complete
BM	= Floor center
BE	= Floor panel end/beginning
BEO	= Floor panel top/end/beginning
BEM	= Floor panel center/end/beginning
BEU	= Floor panel bottom/end/beginning
BMO	= Floor panel center/top/bottom
BMM	= Floor panel center/center
DK	= Ceiling panel complete
DM	= Ceiling panel center
DE	= Ceiling panel end/beginning
DEO	= Ceiling panel top/end/beginning
DEM	= Ceiling panel center/end/beginning
DEU	= Ceiling panel bottom/end/beginning
DMO	= Ceiling panel center/top/bottom
DMM	= Ceiling panel center/center

In addition, this code also includes the panel-specific number that details the thickness of the insulation as well as the width/height of the panel.

Installation

The installation is generally performed from the inside to the outside. Corner elements are an exception. They can also be installed from the outside to the inside. The 8 mm hexagonal wrench included in the delivery is used for firmly connecting the integrated cam locks. Slight hammer blows at the hexagonal wrench simplify the positioning of the wrench.

Important:

Prior to starting the installation, verify that the installation space is suitable for holding the coldroom (interior height!).

Assembly

Always start with the installation of the floor panels. For coldrooms without floor: Start by attaching the U profile on the structural ground.

Coldrooms without Floor

The U profile holds the wall panels. Use a level to verify the flatness of the ground. In cases of bumps, determine the highest point. Use this point to start the compensating work. The U profile must be entirely level under all circumstances to prevent problems during the following steps of the installation of the coldrooms. We recommend to initially attach the U profile in a level manner on the ground. Individual panels are to be leveled by means of underfilling if necessary. Ensure that all angles align at 90° and the U profile is fixed to the ground at intervals of 30 to 40 cm.

Coldrooms with Floor

Before Installation

Generally, we recommend underfloor aeration by means of underfloor aeration rings. The rings are made of plastic; their diameter is 210mm. The rings always come on the same pallet as the panels. They enable the fast assembly of the floor panels.

Please take care that the floor panels are put onto the ridge of the upper side of the ring. In addition, the floor space onto which the coldroom is to be placed, must be absolutely even and free of residual materials.

Installation of the floor with underaeration rings

1. Mark the outline of the coldrooms by means of a marker or chalk on the ground of the installation space. Remember to maintain a distance of the coldroom to any adjacent walls of the installation space (not less than 50 mm all around).
2. Make sure that the ground is strong enough, entirely level and flat.
3. In cases of bumps, determine the highest point and use it as origin for the aeration rings (if applicable).

4. Put the first ring on the highest point.
5. Drill a whole through the channel in the center of the ring into the concrete ground by using a 5 mm driller.
6. Push a suitable dowel (S 5) through the ring's channel into the drilling.
7. Now push a nail through the ring's channel, or use a full-countersunk screw in order to fix the ring to the concrete floor.
8. Now align the other rings to the first ring, and fix them as described under 5.-7. Level out differences by using metal sheets or similarly suited materials.
- 9. Important: Place the rings according to the following sketch (see next page). The maximum distance between two rings shall not exceed 600 mm.**
10. Now place the floor panels onto the rings, and install the coldroom according to the installation guideline.

Installation of the floor without underfloor aeration rings

1. We generally recommend the use of underfloor aeration rings in order to improve air ventilation around the coldroom and to prevent the accumulation of condensing water.
2. Mark the outline of the coldroom by means of a marker or chalk on the ground of the installation space. Remember to maintain a distance of the coldroom to any adjacent walls of the installation space (not less than 50 mm all around).
3. Make sure that the building's ground is strong enough, entirely level and flat.
4. It is absolutely necessary to level out wrinkles in the building's floor.
5. It is advisable to start the installation with the floor panels at the access/door side of the coldroom for reasons of practicality.
6. After that, assemble the floor panels in accordance with the plan of the coldroom. Tighten the camlocks clockwise to the stop position using the 8 mm hexagonal wrench included in the delivery.
7. After the floor panels have been assembled, once again verify their horizontal arrangement by means of a level. Adjust by wedging, if necessary.

Installation with underfloor aeration rings

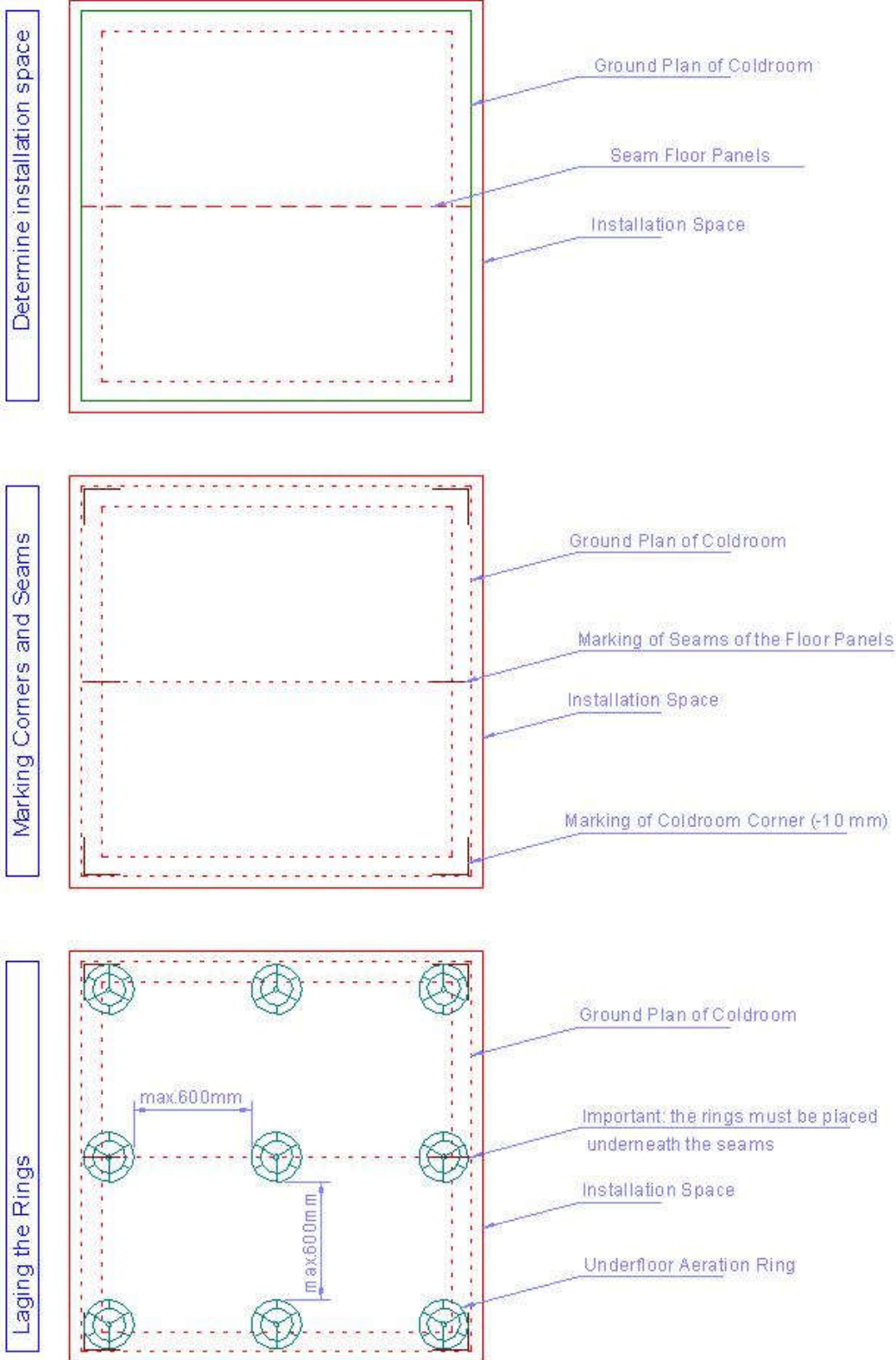

Assembly of the Wall Panels

Assemble exactly in accordance with the plan of the coldroom!

Always proceed from the inside to the outside. We recommend to start at the left front corner and proceed to the right in the following sequence: left wall – rear wall – right wall. Tighten the outside locks of the corner panels in counter-clockwise direction.

As soon as these coldrooms walls are assembled, continue with the assembly of the left front side and simultaneously install the door. Always make sure that the panels are evenly spaced. If cells exhibit interior measurements exceeding 330 cm, two or more panels are arranged on top of each other. In that context, the lower ring of panels must be entirely completed prior to adding the upper ring.

Partition Walls

Install the partition wall prior to installing the outer and/or side panels.

Attention

If the exterior dimensions of the coldrooms are reasonably close to the dimensions of the installation space, generally preassemble the two rear corners and push them as complete corners to the rear! This is important because each corner connection must be locked twice from the outside.

Assembly of the Ceiling Panels

Ceiling without Ceiling Support

Please observe the panel sequence; refer to the coldroom diagram.

Cells with Ceiling Support (Ceiling Carrier)

1. Screw or bolt the carrier consoles to the wall panels. Bolting requires a pilot hole with a diameter of 3.5 mm. Minimum distance to vertical seams = 4 cm
2. Fit the ceiling support
3. Complete assembly in accordance with the plan of the coldroom

Coldrooms with Ceiling Support (Ceiling Suspension)

1. Attach the mounting rail to the provided ceiling panels (refer to the plan of the coldroom). Use the threaded nylon bolts included in the delivery for the attachment.
2. Test the load-bearing capacity of the mount at the structural ceiling prior to the attachment.
3. Connect the coldroom ceiling and the structural ceiling in a vertical manner by means of the tensioning cable.
4. Complete assembly in accordance with the plan of the coldroom

Special Accessories

Deliveries of sliding doors and/or doors of special dimensions include separate assembly instructions.

Comments

1. Remove the protective foil only immediately prior to the initial operation of the coldrooms to prevent scratches.
2. If the coldroom will be used for meat, the seams must be sealed with silicon rubber.
3. In cases of freezers, do not forget the pressure relief valve!
4. The white sealing plugs included in the delivery are used for walls and ceilings, the grey ones for stainless steel and GFK floors.

Chiller Coldrooms

80 mm insulation thickness: recommended temp. range up to + 2°C, for temp. differences up to $\Delta T = 40 \text{ K}$

Modular Dimensions in length and width any 175 mm

Exterior heights in mm	1960	2110	2260	2410	2560
Interior heights in mm	1800	1950	2100	2250	2400

Partition Walls equipped with camlocks all around; can be placed to the cm without any extra charge.

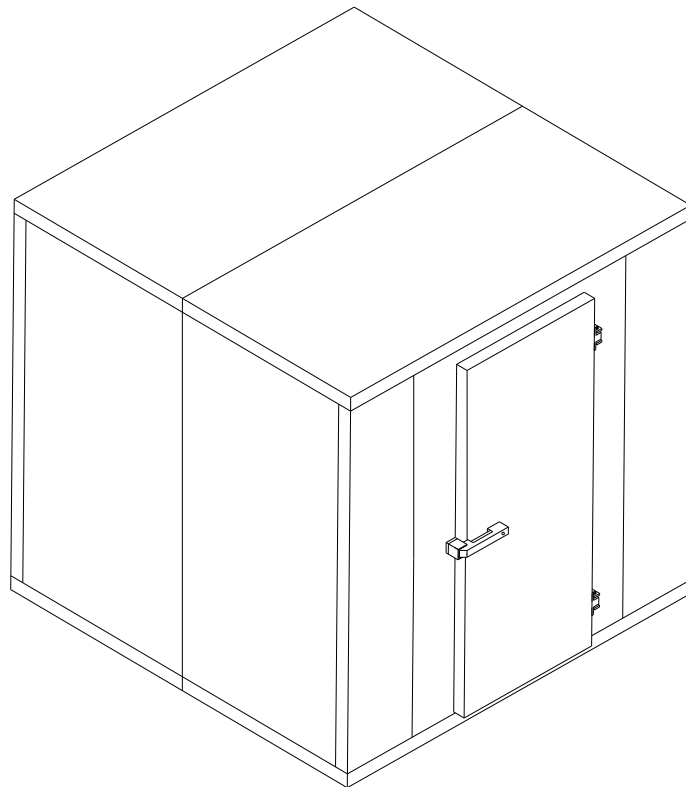

Product description:

Food safe surface

Insulation:

Water-based PUR, foamed entirely without CFC, halogenated CFC, and fluorocarbon, in accordance with the EU Halon Guidelines dated 01.01.2003. Insulation density 40 – 45kg/m³

Cladding:

Wall and ceiling panels consist of hot-galvanised sheet steel coated with foodsafe, white (RAL9002) baked enamel with protective foil for transport and assembly.

Wall design:

All panels are easily assembled thanks to a unique male and female side profile which ensures accurate positioning. Cam locks within the panels give a fast build-up and guarantee a tight, efficient joint.

Hinged door:

The semi-rebated door can be hinged on the right or the left and is supplied fitted on adjustable rising butt hinges. The replaceable door gasket is resistant to fats and acids. The grey Jumbo handle is lockable and incorporates an internal safety release. The following sizes are available of the shelf **without additional cost:**

B= 650/800/1000 H= 1850 mm for exterior height 2110 mm

B= 650/800/1000 H= 2000 mm for exterior height 2260 mm

B= 650/800/1000 H= 2000 mm for exterior height 2410 mm

CELLTHERM standard Floor designs:

GFK-Floor

Anti-slip, reinforced plastic coated surface on waterproof hexagonal birch plywood.

max. permissible load per rubber wheel: 200 kg
 Load bearing surface: 4 cm²
 max. permissible surface load: 30 KN/m²
 Anti-slip class: R11

Stainless Steel

Stainless Steel 0,8mm (1.4301), pattern rolled on waterproof birch plywood (also available in 1,5mm)

max. permissible load per rubber wheel: 200 kg
 Load bearing surface: 4 cm²
 max. permissible surface load: 30 KN/m²
 Anti-slip class: R11 or R12 (w/o extra charge)

Coldroom without floor panels

Plastic U-profile for holding the wall panels, incl. fixtures.
 U-profiles also available in galvanized sheet steel or stainless steel.

Additional floor options on request.

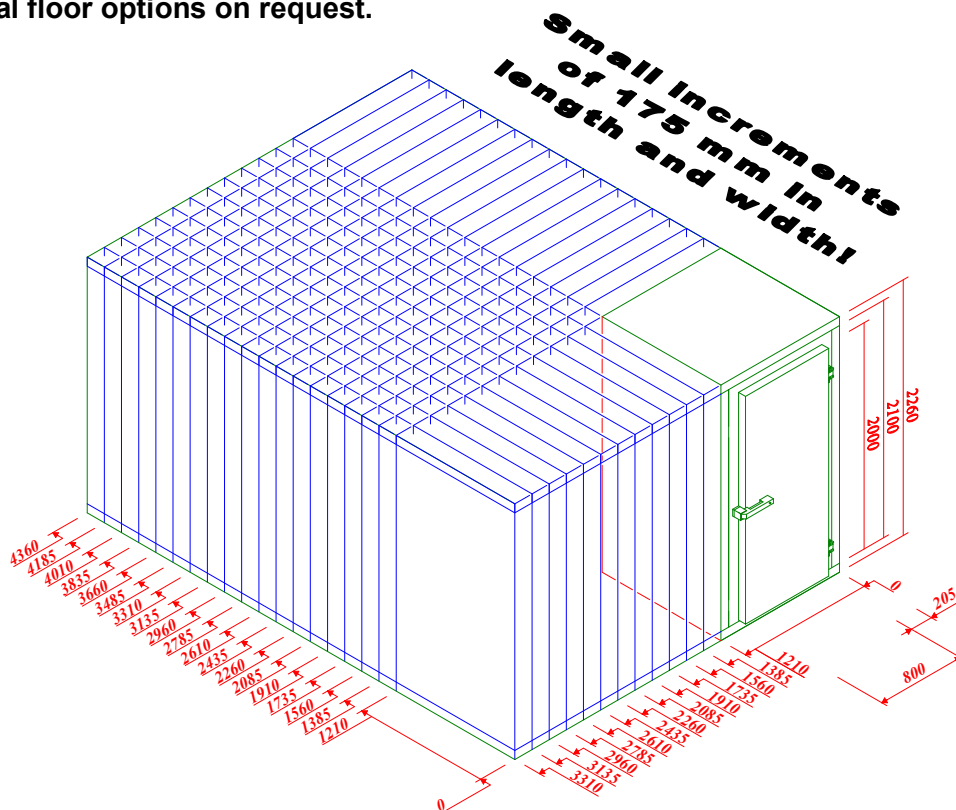

Freezer Coldrooms

80 mm insulation thickness: recommended temp. range up to -10 °C, for temp. differences up to $\Delta T = 40$ K

Modular Dimensions in length and width any 175 mm

Exterior heights in mm	2000	2150	2300	2450	2600
Interior heights in mm	1800	1950	2100	2250	2400

Partition Walls equipped with camlocks all around; can be placed to the cm without any extra charge.

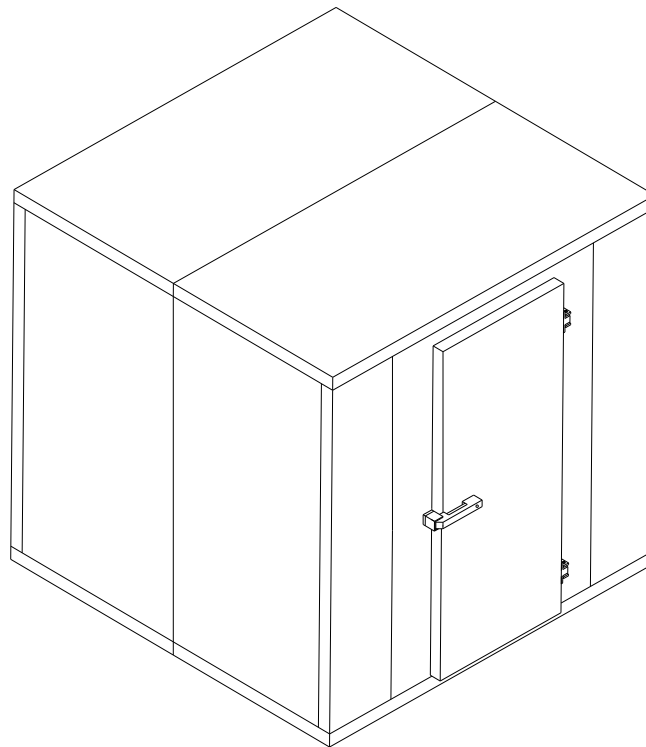

Product description:

Food safe surface

Insulation:

Water-based PUR, foamed entirely without CFC, halogenated CFC, and fluorocarbon, in accordance with the EU Halon Guidelines dated 01.01.2003. Insulation density 40 – 45kg/m³

Cladding:

Wall and ceiling panels consist of hot-galvanised sheet steel coated with foodsafe, white (RAL9002) baked enamel with protective foil for transport and assembly.

Wall design:

All panels are easily assembled thanks to a unique male and female side profile which ensures accurate positioning. Cam locks within the panels give a fast build-up and guarantee a tight, efficient joint.

Hinged door:

The semi-rebated door can be hinged on the right or the left and is supplied fitted on adjustable rising butt hinges. The replaceable door gasket is resistant to fats and acids. The grey Jumbo handle is lockable and incorporates an internal safety release. The following sizes are available of the shelf **without additional cost:**

B= 650/800/1000 H= 1850 mm for exterior height 2150 mm
B= 650/800/1000 H= 2000 mm for exterior height 2300 mm
B= 650/800/1000 H= 2000 mm for exterior height 2450 mm

Equipment for Freezers:

Heated pressure relief valve
Plastic under floor ventilation rings
Door frame equipped with door frame heater

CELLTHERM standard Floor designs:

GFK-Floor

Anti-slip, reinforced plastic coated surface on waterproof hexagonal birch plywood.

max. permissible load per rubber wheel: 200 kg
 Load bearing surface: 4 cm²
 max. permissible surface load: 30 KN/m²
 Anti-slip class: R 11

Stainless Steel

Stainless Steel 0,8mm (1.4301), pattern rolled on waterproof birch plywood (also available in 1,5mm)

max. permissible load per rubber wheel: 200 kg
 Load bearing surface: 4 cm²
 max. permissible surface load: 30 KN/m²
 Anti-slip class: R 11 or R 12 (w/o extra charge)

Coldroom without floor panels

Plastic U-profile for holding the wall panels, incl. fixtures.
 U-profiles also available in galvanized sheet steel or stainless steel.

Additional floor options on request.

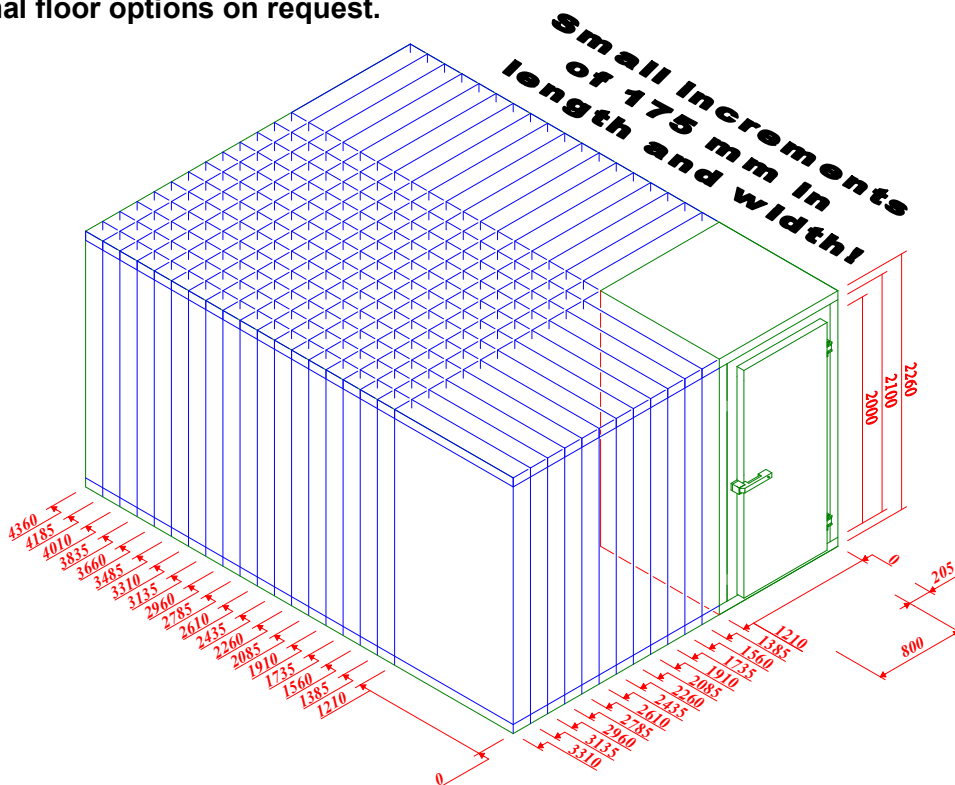

Freezer Coldrooms

100 mm insulation thickness: recommended temp. range up to -20°C, for temp. differences up to $\Delta T = 50 \text{ K}$

Modular Dimensions in length and width any 175 mm

Exterior heights in mm	2040	2190	2340	2490	2640
Interior heights in mm	1800	1950	2100	2250	2400

Partition Walls equipped with camlocks all around; can be placed to the cm without any extra charge.

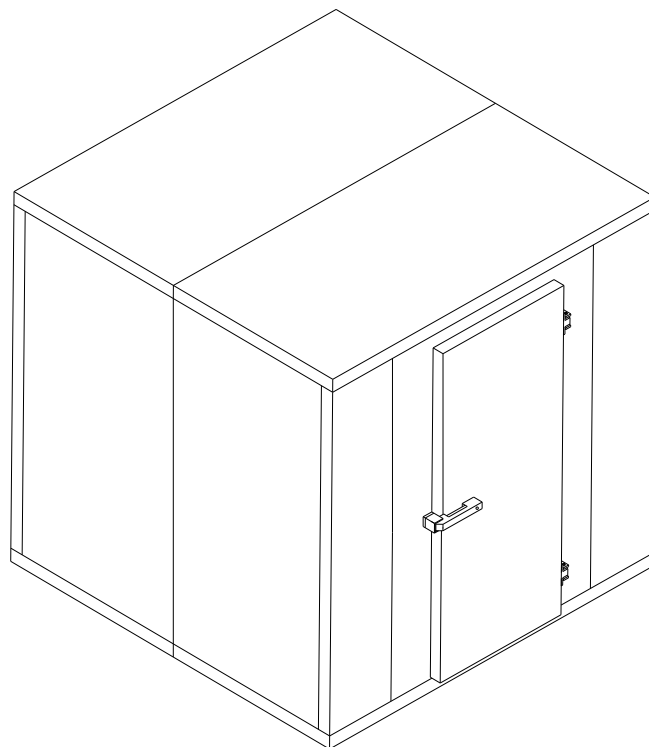

Product description:

Food safe surface

Insulation:

Water-based PUR, foamed entirely without CFC, halogenated CFC, and fluorocarbon, in accordance with the EU Halon Guidelines dated 01.01.2003. Insulation density 40 – 45kg/m³

Cladding:

Wall and ceiling panels consist of hot-galvanised sheet steel coated with foodsafe, white (RAL9002) baked enamel with protective foil for transport and assembly.

Wall design:

All panels are easily assembled thanks to a unique male and female side profile which ensures accurate positioning. Camlocks within the panels give a fast build-up and guarantee a tight, efficient joint.

Hinged door:

The semi-rebated door can be hinged on the right or the left and is supplied fitted on adjustable rising butt hinges. The replaceable door gasket is resistant to fats and acids. The grey Jumbo handle is lockable and incorporates an internal safety release. The following sizes are available of the shelf **without additional cost:**

B= 650/800/1000 H= 1850 mm for exterior height 2190 mm
 B= 650/800/1000 H= 2000 mm for exterior height 2340 mm
 B= 650/800/1000 H= 2000 mm for exterior height 2490 mm

Equipment for Freezers:

Heated pressure relief valve
 Plastic under floor ventilation rings
 Door frame equipped with door frame heater

CELLTHERM standard Floor designs:

GFK-Floor

Anti-slip, reinforced plastic coated surface on waterproof hexagonal birch plywood.

max. permissible load per rubber wheel: 200 kg
 Load bearing surface: 4 cm²
 max. permissible surface load: 30 KN/m²
 Anti-slip class: R 11

Stainless Steel

Stainless Steel 0,8mm (1.4301), pattern rolled on waterproof birch plywood (also available in 1,5mm)

max. permissible load per rubber wheel: 200 kg
 Load bearing surface: 4 cm²
 max. permissible surface load: 30 KN/m²
 Anti-slip class: R 11 or R 12 (w/o extra charge)

Additional floor options on request.

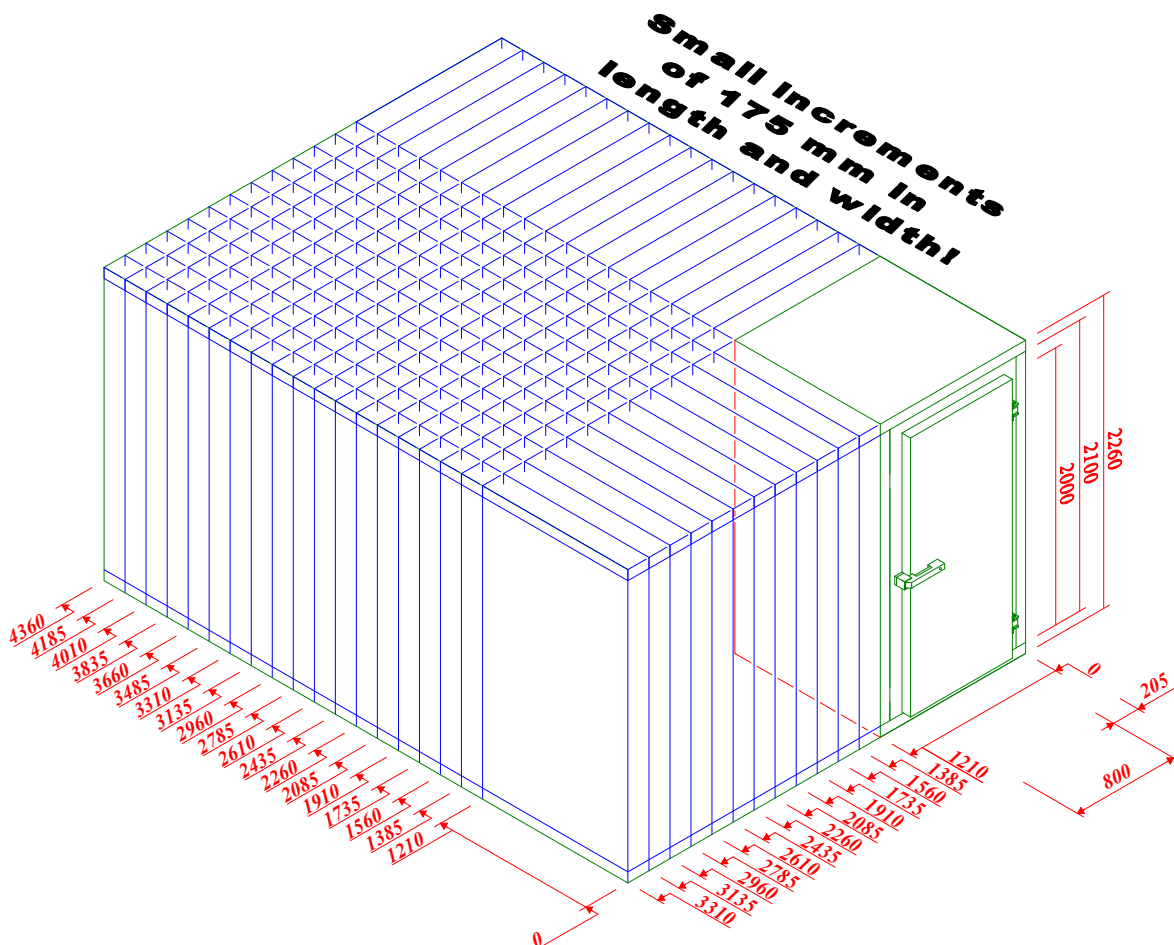

Freezer Coldrooms

120 mm insulation thickness: recommended temp. range up to -30°C , for temp. differences up to $\Delta T = 55\text{ K}$

Modular Dimensions in length and width any 175 mm

Exterior heights in mm	2080	2230	2380	2530	2680
Interior heights in mm	1800	1950	2100	2250	2400

Partition Walls equipped with camlocks all around; can be placed to the cm without any extra charge.

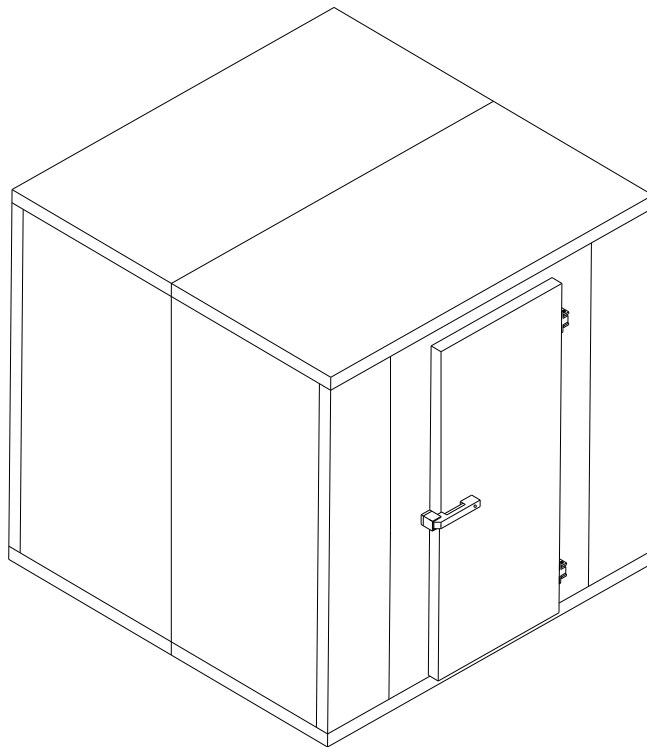

Product description:

Food safe surface

Insulation:

Water-based PUR, foamed entirely without CFC, halogenated CFC, and fluorocarbon, in accordance with the EU Halon Guidelines dated 01.01.2003. Insulation density $40 - 45\text{kg/m}^3$

Cladding:

Wall and ceiling panels consist of hot-galvanised sheet steel coated with foodsafe, white (RAL9002) baked enamel with protective foil for transport and assembly.

Wall design:

All panels are easily assembled thanks to a unique male and female side profile which ensures accurate positioning. Camlocks within the panels give a fast build-up and guarantee a tight, efficient joint.

Hinged door:

The semi-rebated door can be hinged on the right or the left and is supplied fitted on adjustable rising butt hinges. The replaceable door gasket is resistant to fats and acids. The grey Jumbo handle is lockable and incorporates an internal safety release. The following sizes are available of the shelf **without additional cost:**

B= 650/800/1000 H= 1850 mm for exterior height 2230 mm
 B= 650/800/1000 H= 2000 mm for exterior height 2380 mm
 B= 650/800/1000 H= 2000 mm for exterior height 2530 mm

Equipment for Freezers:

Heated pressure relief valve
 Plastic under floor ventilation rings
 Door frame equipped with door frame heater

CELLTHERM standard Floor designs:

GFK-Floor

Anti-slip, reinforced plastic coated surface on waterproof hexagonal birch plywood.

max. permissible load per rubber wheel: 200 kg
 Load bearing surface: 4 cm²
 max. permissible surface load: 30 KN/m²
 Anti-slip class: R 11

Stainless Steel

Stainless Steel 0,8mm (1.4301), pattern rolled on waterproof birch plywood (also available in 1,5mm)

max. permissible load per rubber wheel: 200 kg
 Load bearing surface: 4 cm²
 max. permissible surface load: 30 KN/m²
 Anti-slip class: R 11 or R 12 (w/o extra charge)

Additional floor options on request.

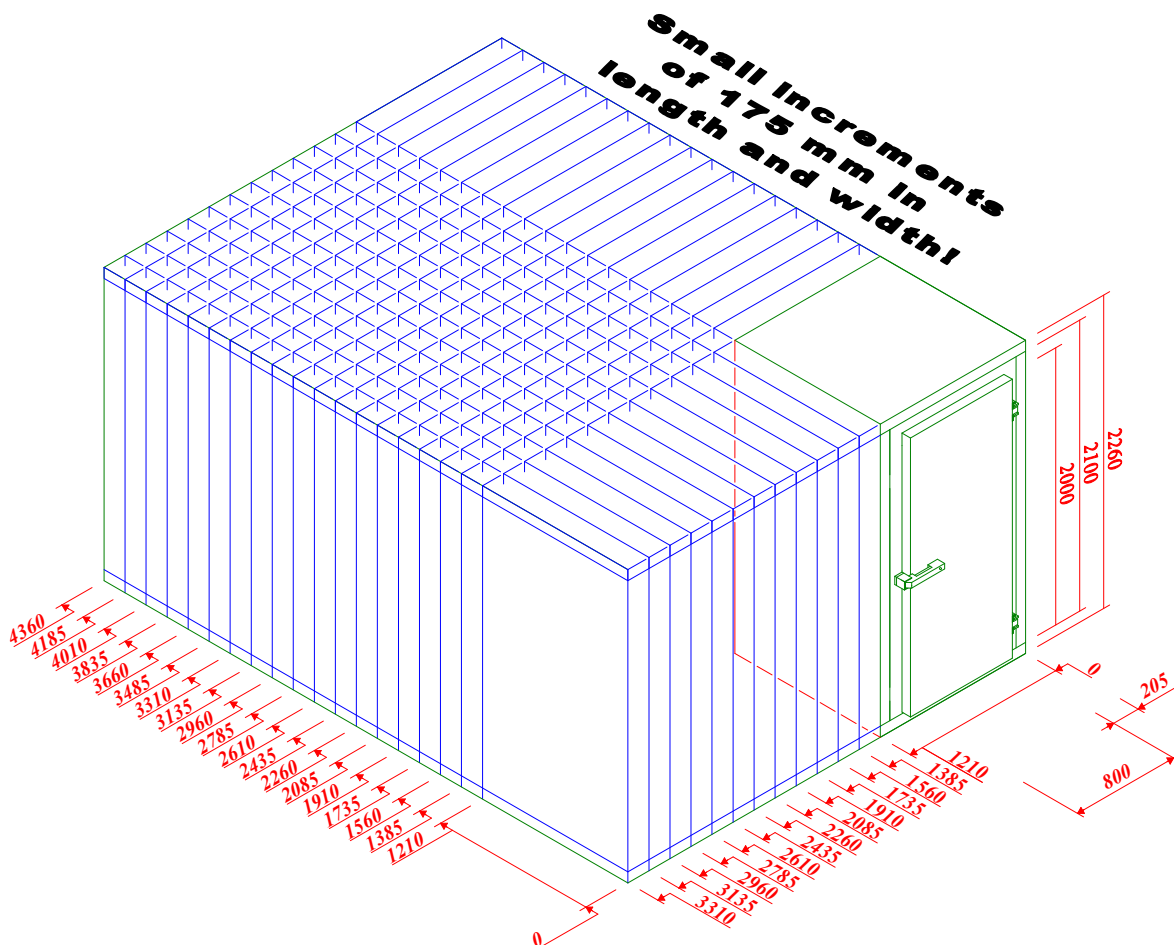

Freezer Coldrooms

150 mm insulation thickness: recommended temp. range up to -45°C , for temp. differences up to $\Delta T = 55 \text{ K}$

Modular Dimensions in length and width any 175 mm

Exterior heights in mm	2290	2440	2590	2740
Interior heights in mm	1950	2100	2250	2400

Partition Walls equipped with camlocks all around; can be placed to the cm without any extra charge.

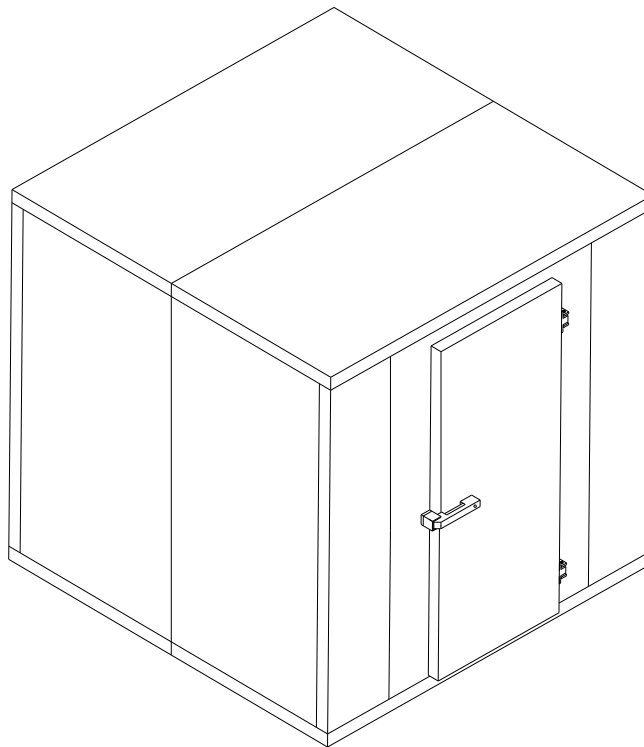

Product description:

Food safe surface

Insulation:

Water-based PUR, foamed entirely without CFC, halogenated CFC, and fluorocarbon, in accordance with the EU Halon Guidelines dated 01.01.2003. Insulation density $40 - 45\text{kg/m}^3$

Cladding:

Wall and ceiling panels consist of hot-galvanised sheet steel coated with foodsafe, white (RAL9002) baked enamel with protective foil for transport and assembly.

Wall design:

All panels are easily assembled thanks to a unique male and female side profile which ensures accurate positioning. Camlocks within the panels give a fast build-up and guarantee a tight, efficient joint.

Hinged door:

The semi-rebated door can be hinged on the right or the left and is supplied fitted on adjustable rising butt hinges. The replaceable door gasket is resistant to fats and acids. The grey Jumbo handle is lockable and incorporates an internal safety release. The following sizes are available of the shelf **without additional cost:**

B= 650/800/1000 H= 1850 mm for exterior height 2290 mm
 B= 650/800/1000 H= 2000 mm for exterior height 2440 mm
 B= 650/800/1000 H= 2000 mm for exterior height 2590 mm

Equipment for Freezers:

Heated pressure relief valve
 Plastic under floor ventilation rings
 Door frame equipped with door frame heater

CELLTHERM standard Floor designs:

GFK-Floor

Anti-slip, reinforced plastic coated surface on waterproof hexagonal birch plywood.

- max. permissible load per rubber wheel: 200 kg
- Load bearing surface: 4 cm²
- max. permissible surface load: 30 KN/m²
- Anti-slip class: R 11

Stainless Steel

Stainless Steel 0,8mm (1.4301), pattern rolled on waterproof birch plywood (also available in 1,5mm)

- max. permissible load per rubber wheel: 200 kg
- Load bearing surface: 4 cm²
- max. permissible surface load: 30 KN/m²
- Anti-slip class: R 11 or R 12 (w/o extra charge)

Additional floor options on request.

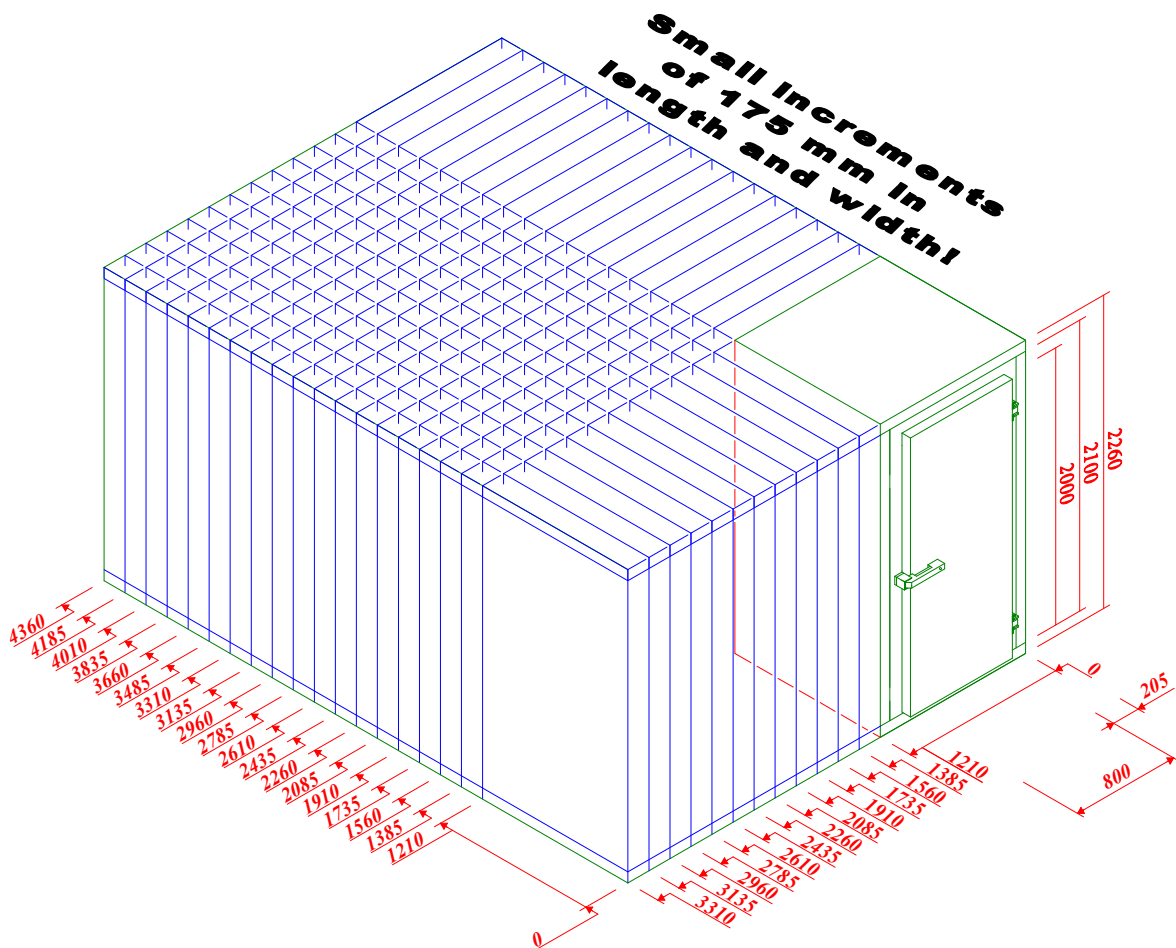

1. Single leaf hinged doors in panel frames

- Standard insulation thickness 100 mm PUR
- Design entirely free of wood
- Lock standard: Jumbo handle with internal safety release in RAL 7001
- Standard finish: galvanised sheet steel coated with foodsafe, white (RAL9002) baked-on enamel
- Rising butt hinges adjustable in all dimensions, powder-coated in RAL 7001
- Safety lock with internal safety release
- Easily replaceable door gaskets, resistant to fats and acids
- Threshold consisting of stainless steel (1.4301)
- Door and door frame profiles extruded from a special plastic, highly resistant to impact
- Deep-freeze room doors with heaters (230 V) in accordance with VDE regulations

Product description

Doors: The semi-rebated door can be hinged on the right or the left and is supplied fitted on adjustable rising butt hinges. The replaceable door gasket is resistant to fats and acids. The grey Jumbo handle is lockable and incorporates an internal safety release.

Doors for deep-freeze applications include a door frame heater and a heated pressure relief valve. Door and door frame profiles are extruded from a special plastic, highly resistant to impact and suitable for temperatures down to -65°C . A stainless steel threshold plate is supplied as standard.

Surface: The following materials are available as surface material for the doors:

- Galvanised sheet steel with a zinc-colour-coating, baked-on enamel, colour RAL 9002
- Galvanized sheet steel, powder-coated, available in all RAL colours
- V2A material number 1.4301-AISI 304 in various surface structures
- V4A material number 1.4401-AISI 316 in various surface structures
- Colour in various surface structures

In addition, all panels include a protective foil to be removed after assembly.

Additional finishes are available upon request!

2. Single leaf hinged doors for installation in brick walls

- To be mounted at or in brick structures
- Standard insulation thickness 100 mm PUR
- Design entirely free of wood
- Lock standard: Jumbo handle with internal safety release in RAL 7001
- Standard finish: galvanised sheet steel coated with foodsafe, white (RAL9002) baked-on enamel
- Rising butt hinges, adjustable, in all dimensions, powder-coated in RAL 7001
- Safety lock with internal safety release
- Easily replaceable door gaskets, resistant to fats and acids
- Door and door frame profiles extruded from a special plastic, highly resistant to impact
- Deep-freeze room doors with heaters (230 V) in accordance with VDE regulations

Additional sizes and finishes are available upon request!

Overview accessories

- Increase of height by each 100 mm
- Threshold in stainless steel (1.4301) – flat sill plate
- Threshold in stainless steel (1.4301) – formed sill plate
- Meat rail flap for rail system, stainless steel finish (only for chillers)
- Dual glazed window, 400 x 600 mm, in stainless steel frame for cooling
- Triple glazed window, 400 x 600 mm, in stainless steel frame, incl. frame heater for deep-freezing
- Inward opening door
- Three-point lock from 2,200 mm
- Fittings prepared for installing KABA cylinders
- Thermal break
- Door contact switch, mechanical
- Door contact switch, inductive
- Additional hinge standard, powder-coated, grey (RAL 7001)
- Additional hinge chromium plated
- Hinge chromium plated
- Door handle chromium plated
- Pressing lever

Optional type: external frame of aluminium

- External frame of aluminium (per running meter)
- Wall cutting for door installation (per running meter)

Additional accessories as well as optional features available upon request!

3. Double leaf hinged doors for installation in brick walls

- To be mounted at or in brick structures
- Standard insulation thickness 100 mm PUR
- Design entirely free of wood
- Lock standard: pressing lever with driving bolt on the inside
- Usage of entire daylight opening possible
- Standard finish: galvanised sheet steel coated with foodsafe, white (RAL9002) baked-on enamel
- Rising butt hinges, adjustable, in all dimensions, powder-coated in RAL 7001
- Safety lock with internal safety release
- Easily replaceable door gaskets, resistant to fats and acids
- Door and door frame profiles extruded from a special plastic, highly resistant to impact
- Deep-freeze room doors with heaters (230 V) in accordance with VDE regulations

Price overview accessories

- Increase of height by each 100 mm
- Threshold in stainless steel (1.4301) – flat sill plate
- Threshold in stainless steel (1.4301) – formed sill plate
- Meat rail flap for rail system, stainless steel finish (only for chillers)
- Dual glazed window, 400 x 600 mm, in stainless steel frame for cooling
- Triple glazed window, 400 x 600 mm, in stainless steel frame, incl. frame heater for deep-freezing
- Three-point lock from 2,200 mm
- Fittings prepared for installing KABA cylinders
- Thermal break
- Door contact switch, mechanical
- Door contact switch, inductive
- Additional hinge standard, powder-coated, grey (RAL 7001)
- Additional hinge chromium plated
- Door handle chromium plated
- Pressing lever

Optional design: external frame of aluminium

- External frame of aluminium (per running meter)
- Wall cutting for door installation (per running meter)

NOTE:

If this door is mounted in a coldroom without floor panels, please do not forget to make a pocket in the structural ground for the driving bolt.

Additional accessories as well as optional features available upon request!

4. Hatches

- Standard insulation thickness 100 mm PUR
- Entirely free of wood
- Lock standard, Ergo handle chromium plated, lockable, without emergency opener
- Standard finish: galvanised sheet steel, foodsafe baked-on enamel, white RAL 9002
- Rising butt hinges adjustable in all dimensions, powder-coated in RAL 7001, optional chromium plating
- Easily replaceable door gaskets, resistant to fats and acids
- Hatch and hatch frame profiles extruded from a special plastic, highly resistant to impact
- Hatches used in deep-freeze areas exhibit heaters (230 V) in accordance with VDE regulations

Product description

Hatches: Hatches for chilling or deep-freezing that can be opened to the outside. They are supported with a replaceable gasket resistant to fats and acids and adjustable rising butt hinges. Lockable Ergo handle, can optionally be hinged left or right.

Hatches used for deep-freeze applications include a frame heater. Hatches and hatch frame profiles extruded from a special plastic, highly resistant to impact, suitable for temperatures down to -65°C .

Surface: The following materials are available as surface material for the hatches:

- Prime galvanised sheet steel with a zinc-colour-coating, foodsafe baked-on enamel, colour RAL 9002
- Galvanised sheet steel, powder-coated, available in all RAL colours
- V2A material number 1.4301-AISI 304 in various surface structures
- V4A material number 1.4401-AISI 316 in various surface structures
- Colour in various surface structures

In addition, all elements include a protective foil to be removed after assembly.

Additional finishes available upon request!

Accessories

Additional hinge standard, powder-coated, grey (RAL 7001)

Additional hinge chromium plated

Additional sizes and special hatches (revision hatches) available upon request!

5. Sliding doors for Chillers

- To be mounted at or in brick structures
- Standard insulation thickness 100 mm PUR
- Design entirely free of wood
- Lock standard non-lockable
- Standard finish: galvanised sheet steel coated with foodsafe, white (RAL9002) baked-on enamel
- Safety lock with internal safety release
- Easily replaceable door gaskets, resistant to fats and acids
- Door and door frame profiles extruded from a special plastic, highly resistant to impact

Price overview accessories

- Increase of height by each 100 mm
- Internal sliding door, lockable from the outside, with reverse lock
- Meat rail flap for rail system, stainless steel finish (for chillers only)
- Meat rail flap door protection, stainless steel finish
- Frame prepared for flip-flap door
- E-automatic in accordance with UVV guidelines (structural E-connection)
- Pull switch open automatic door
- Staff passage and automatic supply (emergency door)
- Safety railing, galvanised, in the dimensions of the door leaf
- Ram protection, galvanised
- Ram protection, stainless steel

Optional design: external frame of aluminium

- External frame of aluminium (per running meter)
- Wall cutting for door installation (per running meter)

Additional accessories as well as optional features upon request!

6. Sliding doors for Freezers

- Installation type at or in brick structures
- Standard insulation thickness 100 mm PUR
- Design entirely free of wood
- Lock standard non-lockable
- Standard finish: galvanised sheet steel, foodsafe baked-on enamel, white RAL 9002
- Safety lock with internal safety release
- Easily replaceable door gaskets, resistant to fats and acids
- Door and door frame profiles extruded from a special plastic, highly resistant to impact
- Deep-freeze room doors with heaters (230 V) in accordance with VDE regulations

Price overview accessories

- Increase of height by each 100 mm
- Internal sliding door, lockable from the outside, with reverse lock
- Frame prepared for flip-flap door
- E-automatic in accordance with UVV guidelines (structural E-connection)
- Pull switch open automatic door
- Staff passage and automatic supply (emergency door)
- Safety railing, galvanised, in the dimensions of the door leaf
- Ram protection, galvanised
- Ram protection, stainless steel

Optional design: external frame of aluminium

- External frame of aluminium (per running meter)
- Wall cutting for door installation (per running meter)

Additional accessories as well as optional features upon request!

7. Glass doors

CELLTHERM provides a wide variety of glass doors (both walk-in and roll-in) which can be installed in chillers and freezers. Complete frames from 1 to 5 doors which can also be combined with each other.

- Double or triple glazing
- Frame heater, optional door and glass heater
- High quality colour profiles
- Doors self-closing
- Lighting for each door
- Thermal break protects from the formation of ice
- Doors can optionally hinged left or right
- The following door sizes are available for chillers and freezers:
660 / 760 x 1601 mm
660 / 760 x 1806 mm

Example for installation:

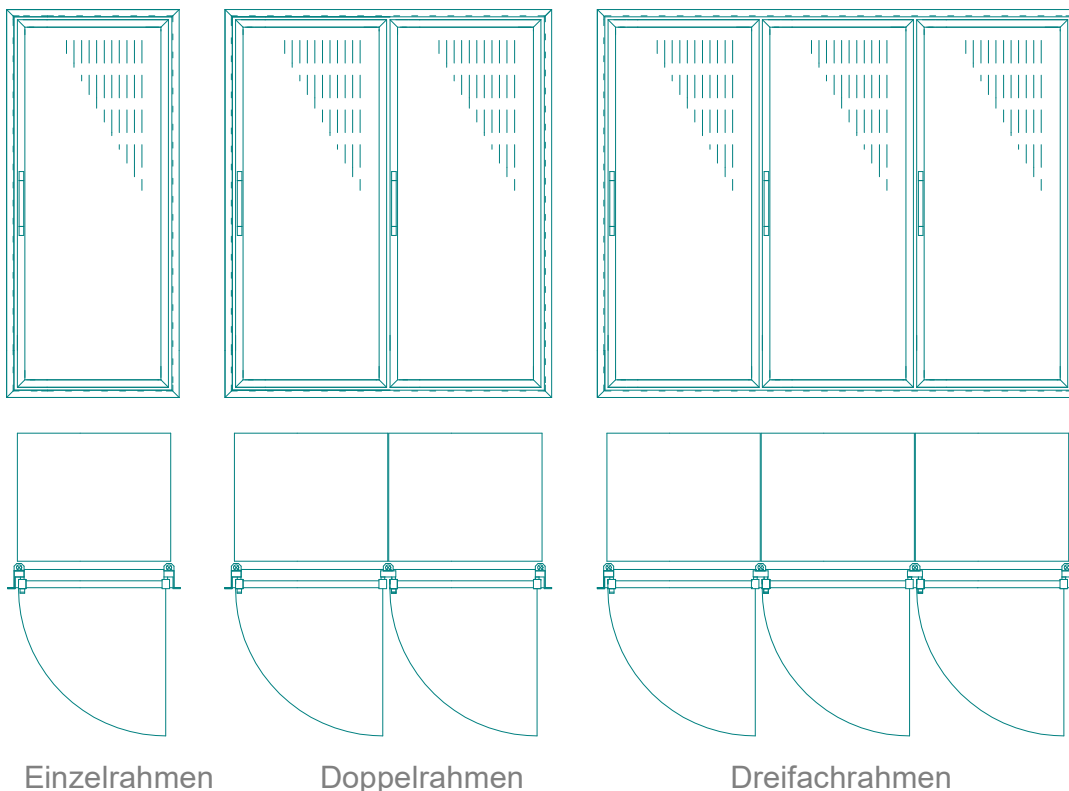

More types such as double leaf glass doors or roll-in glass doors available upon request!

Door sizes and prices as well as sliding shelving systems are available upon request!

8. Sectional Doors, Rolling Doors, Swing Doors

You need sectional or rolling doors for chiller rooms?

Do not hesitate to ask for our great variety of insulated sectional doors and rolling doors. We would love to give you some advice.

The same holds true for our swing doors, which we are offering in stainless steel, PE (five different colours) and transparent PETG for chiller rooms and in PVC for both chiller and freezer rooms.

Accessories for CELLTHERM Coldrooms

Accessory	Specification
-----------	---------------

Partition walls	Partition Walls equipped with camlocks; can be placed to the cm without extra charge.
------------------------	--

- Insulation thickness PUR 80 mm
- Insulation thickness PUR 100 mm
- Insulation thickness PUR 120 mm
- Insulation thickness PUR 150 mm
- Thermal break (for chilling/deep-freeze combinations)
- Partition walls installed by means of angular profile (w/o) camlocks also available

Mounting profiles

- Angular aluminum profiles white 25 x 25 x 2 mm
- Angular aluminum profiles white 40 x 40 x 2 mm
- Flat aluminum profiles white 40 x 2 mm
- Flat aluminum profiles white 60 x 3 mm
- Flat aluminum profiles white 80 x 3 mm
- Angular V2A profiles 25 x 25 x 0.8 mm
- Angular V2A profiles 40 x 40 x 0.8 mm
- Flat stainless steel profiles 40 x 0.8 mm
- Flat stainless steel profiles 60 x 1.5 mm
- Flat stainless steel profiles 80 x 1.5 mm

Other access. (for chiller and freezer rooms)

- Pressure relief valve, electrically heated
- Remote thermometer installed in a calibrated manner
- Remote thermometer installed in a non-calibrated manner
- Lighting (vessel armature) complete, area switch with foamed-in control light
- Lighting with motion detector
- Inspection panel Ø 250 mm without heater installed in the door leaf
- Crash barrier consisting of ND polyethylene 15 x 150 mm, milled and framed
- Crash barrier consisting of ND polyethylene 30 x 150 mm, milled and framed
- Underfloor aeration ring (diameter: 210 mm; height: 40/30/20 mm)
- Ceiling suspension at existing roof construction consisting of: washer, cap, threaded bolt, lock, galvanised steel rope
- Ventilation grille, installed in the door leaf
- Floor drain, Ø 40 mm for water installed without slope in the floor
- Floor lining in RAL 9002 for cells with underfloor aeration rings
- Floor lining in RAL 9002 with aeration slots
- Floor lining in stainless steel for coldrooms with aeration rings
- Floor lining in stainless steel with aeration slots

Identification

Specification

- Plastic U profile for PUR 80 mm
- Plastic U profile for PUR 120 mm
- U profile of 1.5 mm galvanised sheet steel for PUR 80 mm
- U profile of 1.5 mm galvanised sheet steel for PUR 100 mm
- U profile of 1.5 mm galvanised sheet steel for PUR 120 mm
- U profile of 1.5 mm galvanised sheet steel for PUR 150 mm
- U profile of 1.5 mm stainless steel for PUR 80 mm
- U profile of 1.5 mm stainless steel for PUR 100 mm
- U profile of 1.5 mm stainless steel for PUR 120 mm
- U profile of 1.5 mm stainless steel for PUR 150 mm

Panels

- Special panel not fitting the standard increment etc.
- Special finish (V2A, aluminum white, aluminum stucco etc.)
- Sawing costs (for producing special sizes without locks)
- Faceplates (with or without reinforcement inserts)

Ceiling carriers

(Rectangular pipe as interior carrier in RAL 9002, primed as exterior carrier)

- up to 455 cm free span 100 x 50 x 3 (int. or ext. dimension)
- Special console (2 per carrier)
- up to 525 cm free span 120 x 60 x 3 (int. or ext. dimension)
- Special console (2 per carrier)
- up to 595 cm free span 120 x 60 x 4 (int. or ext. dimension)
- Special console (2 per carrier)

(IPE profile arranged on the outside, primed)

- IPE 140 - 730 cm free span (exterior coldroom dimension)
- Special console (2 per carrier)
- IPE 160 - 840 cm free span (exterior coldroom dimension)
- Special console (2 per carrier)
- IPE 180 - 950 cm free span (exterior coldroom dimension)
- Special console (2 per carrier)
- IPE 200 - 1070 cm free span (exterior coldroom dimension)
- Special console (2 per carrier)
- IPE 220 - 1180 cm free span (exterior coldroom dimension)
- Special console (2 per carrier)

Accessory

Specification

Access Ramps (Base design consisting of plastic, surface of corrugated aluminum sheet metal 2.5 – 4 mm)

Door width	Height (mm)	Width (mm)	Length (mm)
650 mm	80	700	800
	100	700	1000
	120	700	1200
	160	700	1200
800 mm	80	850	800
	100	850	1000
	120	850	1200
	160	850	1200
900 mm	80	950	800
	100	950	1000
	120	950	1200
	160	950	1200
1000 mm	80	1050	800
	100	1050	1000
	120	1050	1200
	160	1050	1200
1150 mm	80	1200	800
	100	1200	1000
	120	1200	1200
	160	1200	1200
1200 mm	80	1250	800
	100	1250	1000
	120	1250	1200
	160	1250	1200
1330 mm	80	1400	800
	100	1400	1000
	120	1400	1200
	160	1400	1200

Ramps for 150mm insulation thickness on request!

Strip curtains

The CELLTHERM strip curtain consists of glass-clear PVC strips with rounded edges; a width of 300 and 400 mm; a thickness of 3, 4, and 5 mm; and approx. 100, 120, 160, 180, and 200 mm material overlaps depending on the area of application.

Available both in fixed or mobile versions!

Foamed-in reinforcements for strip curtains included

CELLBOX wall-mount chiller (KW) and freezer (TW) units – Propane (R290)

The CELLBOX BLOCK SYSTEMS consist of a ready-to-use condensation unit, a vaporizer, and an electronic temperature controller. They provide a simple solution for various refrigeration applications. They are available in different designs and deliver reliability due to accurate selection of components, our most stringent production and quality controls, and our long-time experience in refrigeration.

GENERAL TECHNICAL CHARACTERISTICS

- **Natural coolant: R290 (Propane)**
- Filling volume coolant < 150 gr per refrigeration circuit (no extra safety measures required)
- High energy efficiency due to thermostatic expansion valves, pressure transmitters and EC-fans
- Extraordinarily environmentally-friendly: more than 40% less emissions compared to former units
- Electronic controller
 - Smart defrost and leak detector
 - Bluetooth connectivity
 - Remote control per App
 - LED display and backlit keyboard
- Hermetic compressors with thermal coil protection
- Air-cooled condensers with unprecedented low noise level
- Operating conditions: + 5 / + 43° C
- Self-supporting housing consisting of galvanised sheets, powder-coated
- CE approval
- Condensed water discharge directly into condensate evaporation bowl
- Heat exchanger with copper pipes and aluminium ribs

CELLBOX KW – Wall-Mount Units for Chilling – Propane

- 5 / + 5 °C

**Compact ready-to-use chilling unit for wall mounting
Piggyback devices, also available as slide-in devices upon request**

Coolant: R290 (Propane)

Standard equipment:

- Electronic controller (LED-display/keyboard; App)
- Switch ON / OFF and light switch
- Power cord 2.5 m with CEE-plug (16A/32A) - Fuse protection provided by customer
- Connection cable 2.5 m for door contact switch
- LED-lighting with 5 m cord
- Heated evaporation bowl for condensate
- High pressure switch
- For ambient temperature of up to 43°C

Refer to pages 6 – 7 for figures and dimensions

Type	CELLBOX KW100-R290 B			CELLBOX KW200-R290 B			CELLBOX KW300-R290 B			CELLBOX KW400-R290 B		
Form	A			A			B			B		
Electrical Parameters												
Voltage Volt/Ph/Hz	230 / 1 / 50			230 / 1 / 50			230 / 1 / 50			230 / 1 / 50		
Power consumption W	540			780			990			1200		
Current consumption A	2,9			4,3			5,4			6,5		
Electrical fuse protection	16A			16A			16A			16A		
Compressor												
Type	hermetic			hermetic			hermetic			hermetic		
Condenser												
Fan (diameter) mm	1 x 254			1 x 254			1 x 300			1 x 300		
Air quantity m ³ / h	600			600			1200			1200		
Vaporizer												
Fan (diameter) mm	1 x 200			1 x 200			2 x 200			2 x 200		
Air quantity m ³ / h	500			500			1000			1000		
Air dispersion m	6,5			6,5			6,5			6,5		
Expansion	Valve			Valve			Valve			Valve		
Type of defrosting	hot gas			hot gas			hot gas			hot gas		
Weight net / gross (kg)	45 / 58 kg			47 / 60 kg			64 / 89 kg			64,5 / 90 kg		
Noise level ¹⁾ db(A)	31,6			31,4			35,5			36,5		
Cooling output W												
Coldroom temperature °C	+5	0	-5	+5	0	-5	+5	0	-5	+5	0	-5
At +32° C outside temp.	1073	938	812	1434	1256	1091	1840	1607	1390	2304	2023	1759
At +43° C outside temp.	955	832	719	1281	1123	975	1577	1373	1186	2054	1795	1554
Coldroom volume m³												
Coldroom temperature °C	+5	0	-5	+5	0	-5	+5	0	-5	+5	0	-5
At +32° C outside temp.	12,6	8,2	5,5	19,9	11,8	8,0	27,6	17,9	10,8	36,7	24,2	15,8
At +43° C outside temp.	6,6	4,5	3,1	9,6	6,6	4,6	13,2	8,6	6,0	21,0	12,4	8,5

All values based on 80mm PUR insulation thickness

Accessories:

- Water-cooled condenser
- Panel for slide-in device
- Cut-out for unit

1) Measured in 10 m distance; variations possible depending on ambient conditions.

CELLBOX KW – Wall-Mount Units for Chilling - Propane

- 5 / + 5 °C

**Compact ready-to-use chilling unit for wall mounting
Piggyback devices, also available as slide-in devices upon request**

Coolant: R290 (Propane)

Standard equipment:

- Electronic controller (LED-display/keyboard; App)
- Switch ON / OFF and light switch
- Power cord 2.5 m with CEE-plug (16A/32A) - Fuse protection provided by customer
- Connection cable 2.5 m for door contact switch
- LED-lighting with 5 m cord
- Heated evaporation bowl for condensate
- High pressure switch
- For ambient temperature of up to 43°C

Refer to page 8 for figures and dimensions

Type	CELLBOX KW500-R290 B			CELLBOX KW600-R290 B			CELLBOX KW700-R290 B			CELLBOX KW800-R290 B		
Form	C			C			C			C		
Electrical Parameters												
Voltage Volt/Ph/Hz	230 / 1 / 50			230 / 1 / 50			230 / 1 / 50			400 / 3 / 50		
Power consumption W	1490			1870			2000			2440		
Current consumption A	8,1			10,2			10,9			4,4		
Electrical fuse protection	16A			16A			16A			32A		
Compressor												
Type	hermatic			hermatic			hermatic			hermatic		
Condenser												
Fan (diameter) mm	1 x 300			1 x 350			1 x 350			1 x 350		
Air quantity m ³ / h	1200			2540			2540			2540		
Vaporizer												
Fan (diameter) mm	2 x 200			1 x 350			1 x 350			1 x 350		
Air quantity m ³ / h	1000			2740			2740			2740		
Air dispersion m	6,5			8			8			8		
Expansion	Valve			Valve			Valve			Valve		
Type of defrosting	hot gas			hot gas			hot gas			hot gas		
Weight net / gross (kg)	93 / 125 kg			102 / 134 kg			102 / 134 kg			103 / 135 kg		
Noise level¹⁾ db(A)	34,3			42,7			42,5			43,0		
Cooling output W												
Coldroom temperature °C	+5	0	-5	+5	0	-5	+5	0	-5	+5	0	-5
At +32° C outside temp.	2876	2521	2189	3537	3066	2630	3716	3245	2808	4435	3904	3405
At +43° C outside temp.	2574	2255	1956	3130	2691	2286	3199	2785	2406	3964	3473	3015
Coldroom volume m³												
Coldroom temperature °C	+5	0	-5	+5	0	-5	+5	0	-5	+5	0	-5
At +32° C outside temp.	48,4	32,2	21,6	62,3	41,2	27,5	66,1	44,2	30,0	81,6	55,5	38,3
At +43° C outside temp.	28,9	19,2	11,5	37,8	24,7	15,6	38,9	25,9	17,3	52,0	35,1	23,9

All values based on 80mm PUR insulation thickness

Accessories:

- Water-cooled condenser
- Panel for slide-in device
- Cut-out for unit

¹⁾ Measured in 10 m distance; variations possible depending on ambient conditions.

CELLBOX TW – Wall-Mount Units for Freezing - Propane

-15 / -25 °C

Compact ready-to-use chilling unit for wall mounting
Piggyback devices, also available as slide-in devices upon request

Coolant: **R290 (Propane)**

Standard equipment:

- Electronic controller (LED-display/keyboard; App)
- Switch ON / OFF and light switch
- Power cord 2.5 m with CEE-plug (16A/32A) - Fuse protection provided by customer
- Connection cable 2.5 m for door contact switch
- LED-lighting with 5 m cord
- Heated evaporation bowl for condensate
- High pressure switch
- For ambient temperature of up to 43°C

Refer to pages 6-7 for figures and dimensions

Type	CELLBOX TW100-R290 B			CELLBOX TW200-R290 B			CELLBOX TW300-R290 B		
Form	A			A			B		
Electrical Parameters									
Voltage Volt/Ph/Hz	230 / 1 / 50			230 / 1 / 50			230 / 1 / 50		
Power consumption W	690			910			940		
Current consumption A	3,8			5,0			5,1		
Electrical fuse protection	16A			16A			16A		
Compressor									
Type	hermetic			hermetic			hermetic		
Condenser									
Fan (diameter) mm	1 x 254			1 x 254			1 x 300		
Air quantity m³ / h	600			600			1200		
Vaporizer									
Fan (diameter) mm	1 x 200			1 x 200			2 x 200		
Air quantity m³ / h	500			500			1000		
Air dispersion m	6,5			6,5			6,5		
Expansion	Valve			Valve			Valve		
Type of defrosting	hot gas			hot gas			hot gas		
Weight net / gross (kg)	46 / 59 kg			54 / 67 kg			64 / 89 kg		
Noise level¹⁾ db(A)	31,3			32,8			32,8		
Cooling output W									
Coldroom temperature °C	-15	-20	-25	-15	-20	-25	-15	-20	-25
At +32° C outside temp.	782	663	554	1082	919	770	1263	1069	892
At +43° C outside temp.	695	588	491	959	810	675	1111	936	774
Coldroom volume m³									
Coldroom temperature °C	-15	-20	-25	-15	-20	-25	-15	-20	-25
At +32° C outside temp.	7,1	4,6	3,0	11,2	7,4	4,9	15,4	9,1	6,0
At +43° C outside temp.	3,9	2,6	1,7	6,2	4,2	2,8	7,6	5,1	3,4

All values based on 100mm PUR insulation thickness

Accessories:

- Water-cooled condenser
- Panel for slide-in device
- Cut-out for unit

¹⁾ Measured in 10 m distance; variations possible depending on ambient conditions.

CELLBOX TW – Wall-mount Units for Freezing - Propane

-15 / -25 °C

Compact ready-to-use chilling unit for wall mounting
Piggyback devices, also available as slide-in devices upon request

Coolant: R290 (Propane)

Standard equipment:

- Electronic controller (LED-display/keyboard; App)
- Switch ON / OFF and light switch
- Power cord 2.5 m with CEE-plug (16A/32A) - Fuse protection provided by customer
- Connection cable 2.5 m for door contact switch
- LED-lighting with 5 m cord
- Heated evaporation bowl for condensate
- High pressure switch
- For ambient temperature of up to 43°C

Refer to pages 7-8 for figures and dimensions

Type	CELLBOX TW400-R290 B	CELLBOX TW500-R290 B	CELLBOX TW600-R290 B	CELLBOX TW700-R290 B								
Form	B	B	C	C								
Electrical Parameters												
Voltage Volt/Ph/Hz	400 / 3 / 50	230 / 1 / 50	400 / 3 / 50	400 / 3 / 50								
Power consumption W	1180	1300	1800	2300								
Current consumption A	2,1	7,1	3,3	4,2								
Electrical fuse protection	32A	16A	32A	32A								
Compressor												
Type	hermetic	hermetic	hermetic	hermetic								
Condenser												
Fan (diameter) mm	1 x 300	1 x 300	1 x 350	1 x 350								
Air quantity m ³ / h	1200	1200	2540	2540								
Vaporizer												
Fan (diameter) mm	2 x 200	2 x 200	1 x 350	1 x 350								
Air quantity m ³ / h	1000	1000	2740	2740								
Air dispersion m	6,5	6,5	8	8								
Expansion	Valve	Valve	Valve	Valve								
Type of defrosting	hot gas	hot gas	hot gas	hot gas								
Weight net / gross (kg)	68 / 100 kg	93 / 125 kg	101 / 133 kg	110 / 138 kg								
Noise level¹⁾ db(A)	35,5	35,3	42,3	42,5								
Cooling output W												
Coldroom temperature °C	-15	-20	-25	-15	-20	-25	-15	-20	-25	-15	-20	-25
At +32° C outside temp.	1497	1274	1067	1824	1539	1283	2553	2161	1802	3030	2580	2161
At +43° C outside temp.	1309	1109	923	1584	1325	1091	2248	1893	1566	2654	2248	1871
Coldroom volume m³												
Coldroom temperature °C	-15	-20	-25	-15	-20	-25	-15	-20	-25	-15	-20	-25
At +32° C outside temp.	20,8	11,6	7,7	28,3	17,4	10,0	46,9	29,6	18,4	60,1	38,5	24,4
At +43° C outside temp.	9,6	6,5	4,4	13,2	8,4	5,6	25,8	15,7	9,2	33,5	21,4	11,9

All values based on 100mm PUR insulation thickness

Accessories:

- Water-cooled condenser
- Panel for slide-in device
- Cut-out for unit

¹⁾ Measured in 10 m distance; variations possible depending on ambient conditions.

CELLBOX Wall-mount units (R290) – Figures and Dimensions

FORM A

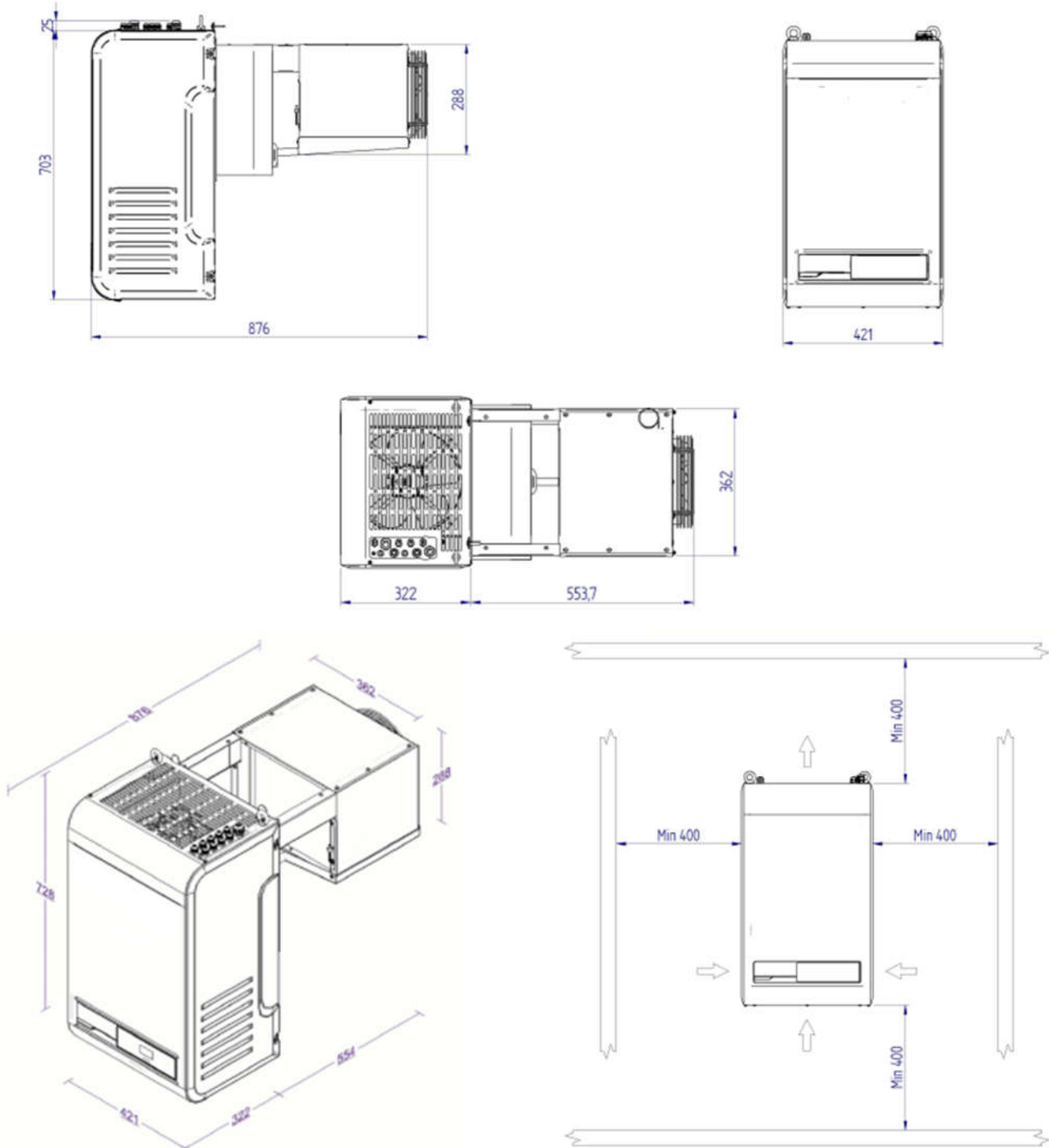

CELLBOX Wall-mount Units (R290) – Figures and Dimensions

FORM B

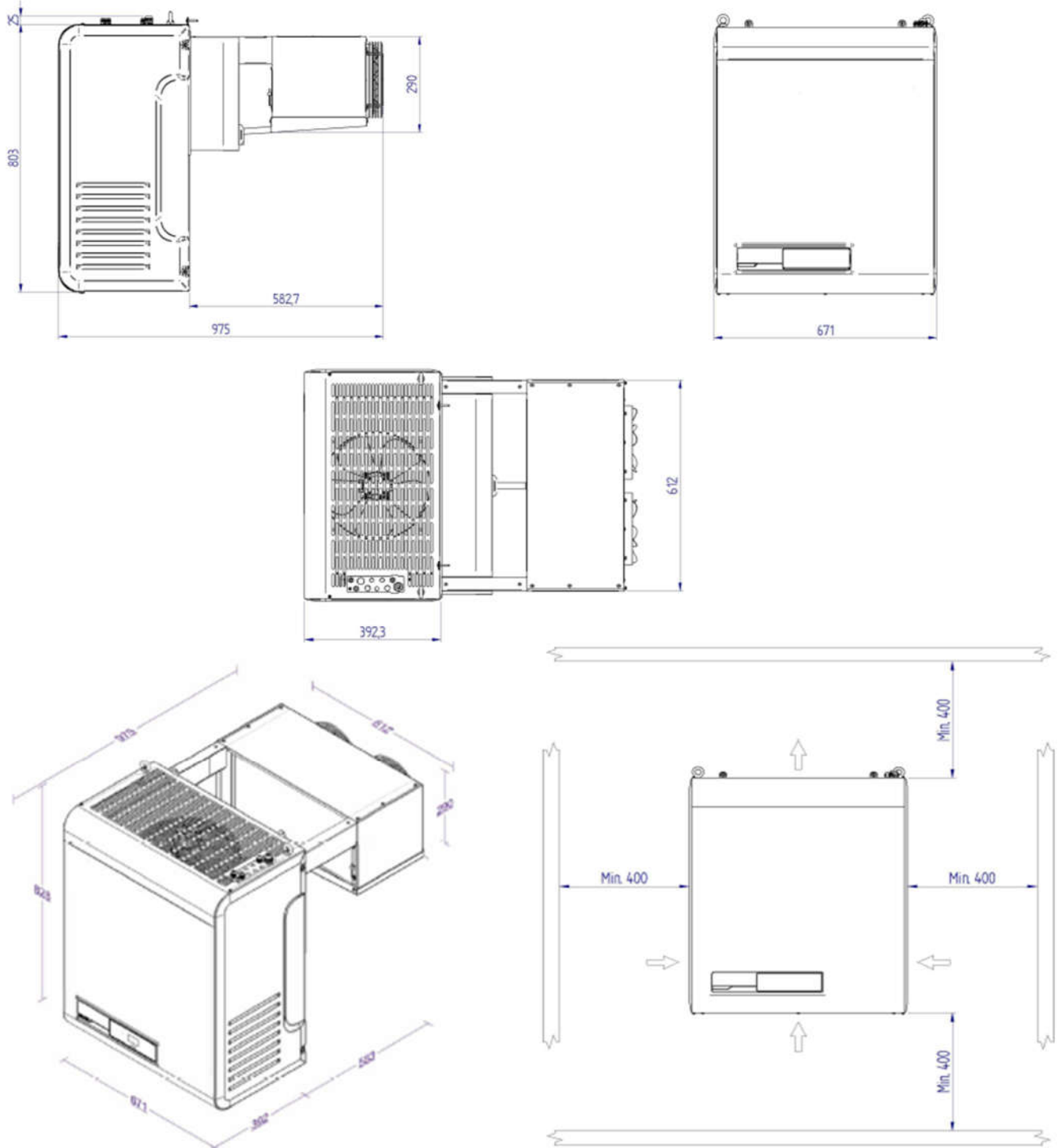

CELLBOX Wall-mount Units (R290) – Figures and Dimensions

FORM C

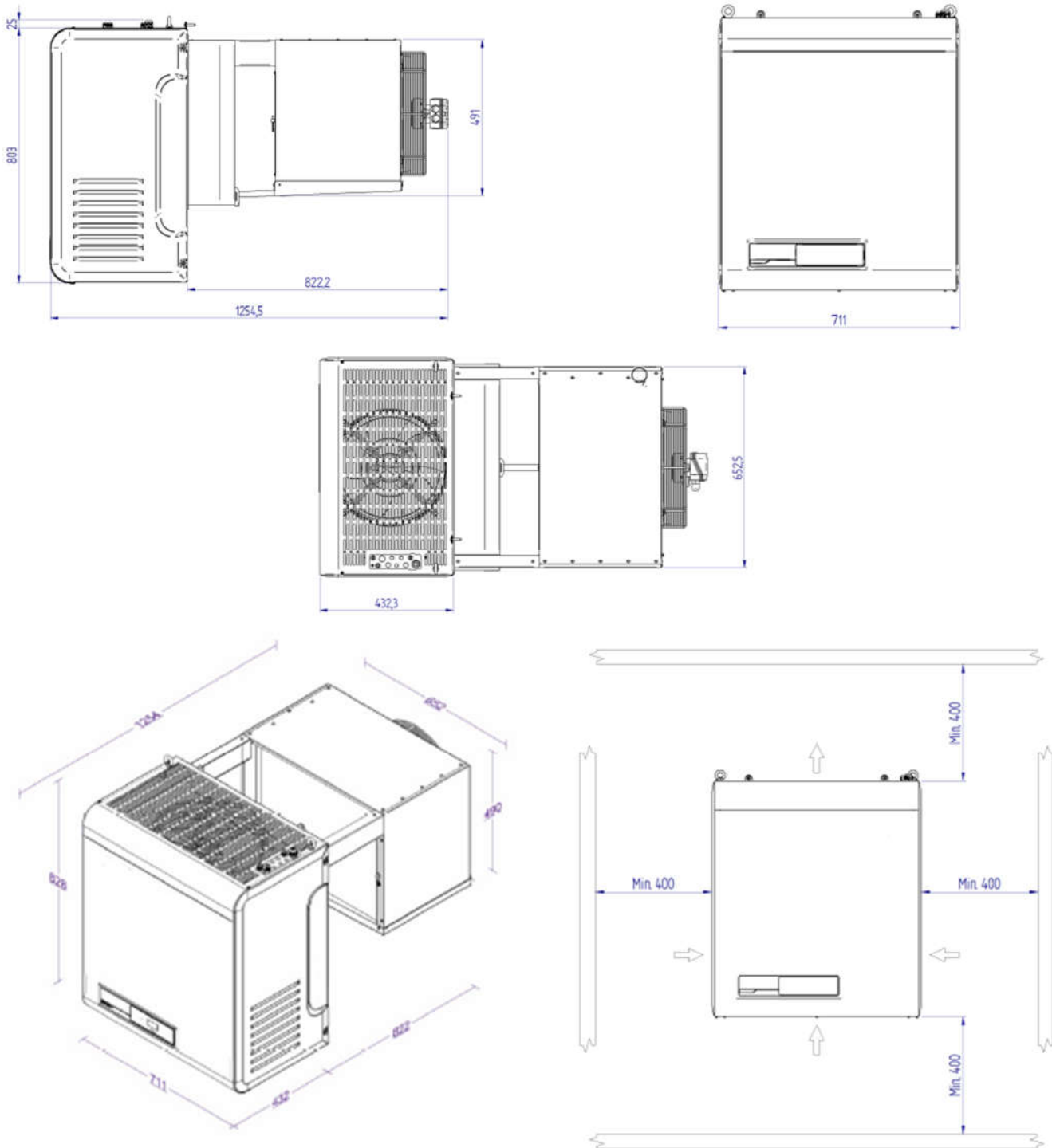

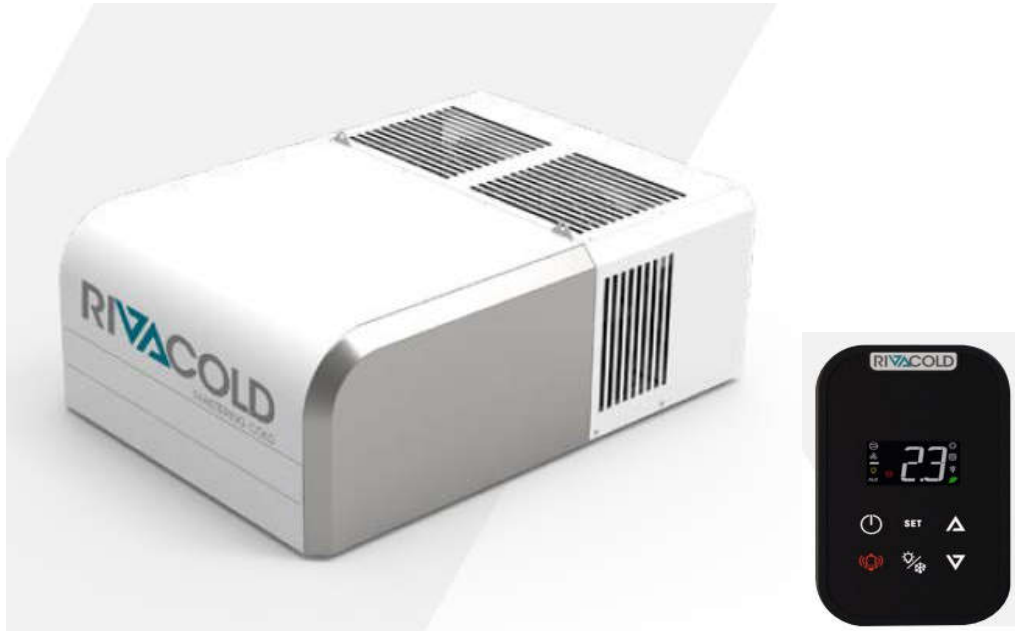
CELLBOX Ceiling units R290 - KD (cooling) und TD (freezing)

CELLBOX ceiling units R290 are factory-manufactured and ready-to-use refrigeration units (monobloc) that contain all components of the complete refrigerant circuit. CELLBOX ceiling units R290 are a simple, economical, and future-proof solution for a wide range of cooling applications. CELLBOX ceiling units R290 are available in various versions and offer impressive reliability and energy efficiency, which we guarantee thanks to the accurate selection and harmonisation of components, strict production and quality control and our many years of experience in the refrigeration sector.

GENERAL TECHNICAL CHARACTERISTICS

- **Refrigerant: R290 (propane)**
- Refrigerant charge <150 g per refrigerant circuit
(according to DIN EN 378, no additional safety device is required)
- Electronic control, can be parameterised to customer specifications if required
- Hermetic compressor with thermal winding protection
- CE conformity
- Min. / max. ambient temperature +5 °C / +43 °C
- Air-cooled condenser (water-cooled versions on request)
- Thermostatic expansion valve (TEV)
- Automatic defrost programmable: Intervals, real time, demand
- Condensate drain directly into condensate evaporation tray
- Heat exchanger made of copper pipes and aluminium fins
- Protection class IP 20
- Connectivity: Bluetooth via APP (standard), Modbus (standard), IoT (optional)

CELLBOX KD – Roof-mount Units for Chilling – Propane

Compact plug-in refrigeration unit for ceiling installation with refrigerant R290 (propane) for coldroom temperatures from -5 to +15 °C.

Standard equipment:

- Electronic control instrument with Bluetooth connectivity
- Remote control panel with 5 m connection cable
- Power cable 2,5 m with 3-pin CEE-plug (1Ph+N+PE) 230V 16A – Fuse protection on site
- Door contact switch with 2.5 m cable
- Lighting with 5 m cable
- Modbus connection with 5 m cable
- Heated evaporation tray for condensation water
- High pressure transmitter
- Low pressure transmitter

For illustrations and installation dimensions, see pages 6 - 7

Type	CELLBOX KD100-R290 B			CELLBOX KD200-R290 B			CELLBOX KD300-R290 B			CELLBOX KD400-R290 B			CELLBOX KD500-R290 B		
Form	CM130			CM130			CM130			CM230			CM230		
Electrical Data															
Voltage Volt/Ph/Hz	230/1/50			230/1/50			230/1/50			230/1/50			230/1/50		
Absorption W	395			570			765			975			1200		
Absorption A	2,1			3,1			4,2			5,3			6,5		
Compressor															
Number and type	1 x hermetic			1 x hermetic			1 x hermetic			1 x hermetic			1 x hermetic		
Condenser															
Fan: number and Ø mm	1 x 300			1 x 300			1 x 300			2 x 300			2 x 300		
Airflow m ³ / h	1100			1100			1100			2450			2450		
Evaporator															
Fan: number and Ø mm	1 x 300			1 x 300			1 x 300			2 x 300			2 x 300		
Luftmenge m ³ / h	750			750			750			1300			1300		
Air throwing range m	3			3			3			4,5			4,5		
Expansion	TEV			TEV			TEV			TEV			TEV		
Defrost	Hotgas			Hotgas			Hotgas			Hotgas			Hotgas		
Weight kg net / gross	64 / 85			65 / 86			65 / 86			90 / 120			97 / 127		
Sound level ¹⁾ db(A)	31,5			31,7			31,5			35,7			36,7		
Cooling capacity W															
Cold room temperature °C	+5	0	-5	+5	0	-5	+5	0	-5	+5	0	-5	+5	0	-5
+32°C ambient temp.	858	737	626	1236	1074	924	1520	1332	1156	1926	1683	1457	2245	1972	1717
+43°C ambient temp.	749	640	541	1093	947	812	1352	1184	1026	1711	1496	1294	2005	1755	1521
Cold room volume m³															
Cold room temperature °C	+5	0	-5	+5	0	-5	+5	0	-5	+5	0	-5	+5	0	-5
+32°C ambient temp.	9,4	6,0	3,9	16,1	9,7	6,5	21,5	13,0	8,6	29,2	19,0	11,5	35,5	23,4	15,2
+43°C ambient temp.	4,8	3,1	2,1	7,8	5,3	3,6	10,4	7,1	5,0	15,7	9,7	6,7	20,3	11,9	8,3

Data for room volumes refer to insulation thickness PUR 80 mm

Accessories for the units (prices on request):

- Water-cooled condenser
- Mounting opening or recess

¹⁾ Measured at a distance of 10 m at nominal power in the installation position. Depending on local conditions and installation position, the values achieved may vary.

CELLBOX KD – Roof-mount Units for Chilling – Propane

Compact plug-in refrigeration unit for ceiling installation with refrigerant R290 (propane) for coldroom temperatures from -5 to +15 °C.

Standard equipment:

- Electronic control instrument with Bluetooth connectivity
- Remote control panel with 5 m connection cable
- Power cable 2,5 m with 3-pin CEE-plug (1Ph+N+PE) 230V 16A – Fuse protection on site
- Door contact switch with 2.5 m cable
- Lighting with 5 m cable
- Modbus connection with 5 m cable
- Heated evaporation tray for condensation water
- High pressure transmitter
- Low pressure transmitter

For illustrations and installation dimensions, see pages 7

Type	CELLBOX KD600-R290 B			CELLBOX KD700-R290 B			CELLBOX KD800-R290 B		
Form	CM230			CM230			CM230		
Electrical Data									
Voltage Volt/Ph/Hz	400/3/50			400/3/50			400/3/50		
Absorption W	1475			1790			2245		
Absorption A	2,8			3,3			4,2		
Compressor									
Number and type	2 x hermetic			2 x hermetic			2 x hermetic		
Condenser									
Fan: number and Ø mm	2 x 300			2 x 300			2 x 300		
Airflow m ³ / h	2300			2300			2300		
Evaporator									
Fan: number and Ø mm	2 x 300			2 x 300			2 x 300		
Luftmenge m ³ / h	1150			1150			1150		
Air throwing range m	4			4			4		
Expansion	TEV			TEV			TEV		
Defrost	Hotgas			Hotgas			Hotgas		
Weight kg net / gross	110 / 140			110 / 140			124 / 154		
Sound level¹⁾ db(A)	34,5			36,8			38,2		
Cooling capacity W									
Cold room temperature °C	+5	0	-5	+5	0	-5	+5	0	-5
+32°C ambient temp.	3078	2698	2341	3521	3097	2698	4053	3584	3140
+43°C ambient temp.	2739	2400	2080	3123	2748	2393	3634	3196	2786
Cold room volume m³									
Cold room temperature °C	+5	0	-5	+5	0	-5	+5	0	-5
+32°C ambient temp.	52,6	35,1	23,7	61,9	41,7	28,4	73,3	50,0	34,6
+43°C ambient temp.	31,5	21,0	12,8	37,7	25,4	17,2	46,2	31,3	21,4

Data for room volumes refer to insulation thickness PUR 80 mm

Accessories for the units (prices on request):

- Water-cooled condenser
- Mounting opening or recess

¹⁾ Measured at a distance of 10 m at nominal power in the installation position. Depending on local conditions and installation position, the values achieved may vary.

CELLBOX KD – Roof-mount Units for Freezer – Propane

Compact plug-in refrigeration unit for ceiling installation with refrigerant R290 (propane) for coldroom temperatures from -10 to -25 °C.

Standard equipment:

- Electronic control instrument with Bluetooth connectivity
- Remote control panel with 5 m connection cable
- Power cable 2,5 m with 3-pin CEE-plug (1Ph+N+PE) 230V 16A – Fuse protection on site
- Connecting cable 5 m zur door frame heater
- Door contact switch with 2.5 m cable
- Lighting with 5 m cable
- Modbus connection with 5 m cable
- Heated evaporation tray for condensation water
- High pressure transmitter
- Low pressure transmitter

For illustrations and installation dimensions, see pages 6 - 7

Type	CELLBOX TD 100-R290 B			CELLBOX TD 200-R290 B			CELLBOX TD 300-R290 B		
Form	CM130			CM130			CM230		
Electrical Data									
Voltage Volt/Ph/Hz	230/1/50			230/1/50			230/1/50		
Absorption W	590			810			1030		
Absorption A	3,2			4,4			5,6		
Compressor									
Number and type	1 x hermetic			1 x hermetic			1 x hermetic		
Condenser									
Fan: number and Ø mm	1 x 300			1 x 300			2 x 300		
Airflow m ³ / h	1100			1100			2450		
Evaporator									
Fan: number and Ø mm	1 x 300			1 x 300			2 x 300		
Luftmenge m ³ / h	750			750			1300		
Air throwing range m	3			3			4,5		
Expansion	TEV			TEV			TEV		
Defrost									
	Hotgas			Hotgas			Hotgas		
Weight kg net / gross	66 / 87			73 / 94			98 / 119		
Sound level ¹⁾ db(A)	31,4			32,9			35,3		
Cooling capacity W									
Cold room temperature °C	-15	-20	-25	-15	-20	-25	-15	-20	-25
+32°C ambient temp.	898	755	625	1176	1000	837	1422	1212	1017
+43°C ambient temp.	792	665	550	1034	875	728	1256	1067	891
Cold room volume m³									
Cold room temperature °C	-15	-20	-25	-15	-20	-25	-15	-20	-25
+32°C ambient temp.	8,6	5,6	3,6	13,1	8,3	5,5	19,2	10,9	7,2
+43°C ambient temp.	4,7	3,1	2,1	6,9	4,7	3,1	9,1	6,2	4,2

Data for room volumes refer to insulation thickness PUR 100 mm

Accessories for the units (prices on request):

- Water-cooled condenser
- Mounting opening or recess

¹⁾ Measured at a distance of 10 m at nominal power in the installation position. Depending on local conditions and installation position, the values achieved may vary.

CELLBOX KD – Roof-mount Units for Freezer – Propane

Compact plug-in refrigeration unit for ceiling installation with refrigerant R290 (propane) for coldroom temperatures from -10 to -25 °C.

Standard equipment:

- Electronic control instrument with Bluetooth connectivity
- Remote control panel with 5 m connection cable
- Power cable 2,5 m with 3-pin CEE-plug (1Ph+N+PE) 230V 16A – Fuse protection on site
- Connecting cable 5 m zur door frame heater
- Door contact switch with 2.5 m cable
- Lighting with 5 m cable
- Modbus connection with 5 m cable
- Heated evaporation tray for condensation water
- High pressure transmitter
- Low pressure transmitter

For illustrations and installation dimensions, see pages 7

Type	CELLBOX TD 400-R290 B			CELLBOX TD 500-R290 B			CELLBOX TD 600-R290 B		
Form	CM230			CM230			CM230		
Electrical Data									
Voltage Volt/Ph/Hz	400/3/50			400/3/50			400/3/50		
Absorption W	1230			1560			1900		
Absorption A	2,4			2,9			3,5		
Compressor									
Number and type	2 x hermetic			2 x hermetic			2 x hermetic		
Condenser									
Fan: number and Ø mm	2 x 300			2 x 300			2 x 300		
Airflow m ³ / h	2300			2300			2300		
Evaporator									
Fan: number and Ø mm	2 x 300			2 x 300			2 x 300		
Luftmenge m ³ / h	1150			1150			1150		
Air throwing range m	4			4			4		
Expansion	TEV			TEV			TEV		
Defrost									
	Hotgas			Hotgas			Hotgas		
Weight kg net / gross	111 / 141			125 / 155			125 / 155		
Sound level ¹⁾ db(A)	34,7			35,9			36,1		
Cooling capacity W									
Cold room temperature °C	-15	-20	-25	-15	-20	-25	-15	-20	-25
+32°C ambient temp.	2026	1706	1416	2382	2025	1695	2624	2249	1898
+43°C ambient temp.	1791	1503	1240	2097	1774	1474	2321	1982	1662
Cold room volume m³									
Cold room temperature °C	-15	-20	-25	-15	-20	-25	-15	-20	-25
+32°C ambient temp.	33,3	20,5	11,4	42,4	26,7	16,6	48,8	31,4	20,0
+43°C ambient temp.	17,8	10,0	6,7	23,0	13,3	8,5	27,1	17,5	10,0

Data for room volumes refer to insulation thickness PUR 100 mm

Accessories for the units (prices on request):

- Water-cooled condenser
- Mounting opening or recess

¹⁾ Measured at a distance of 10 m at nominal power in the installation position. Depending on local conditions and installation position, the values achieved may vary.

Figures and installation dimensions – Form CM130

Packaging Dimensions:

- A = 830 mm
- B = 1.300 mm
- H = 815 mm

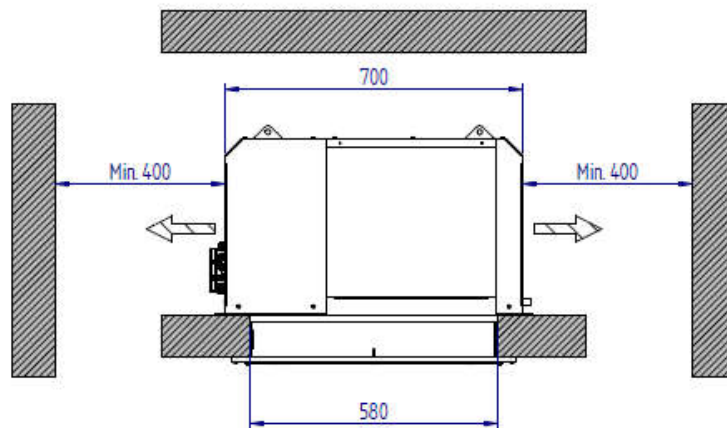
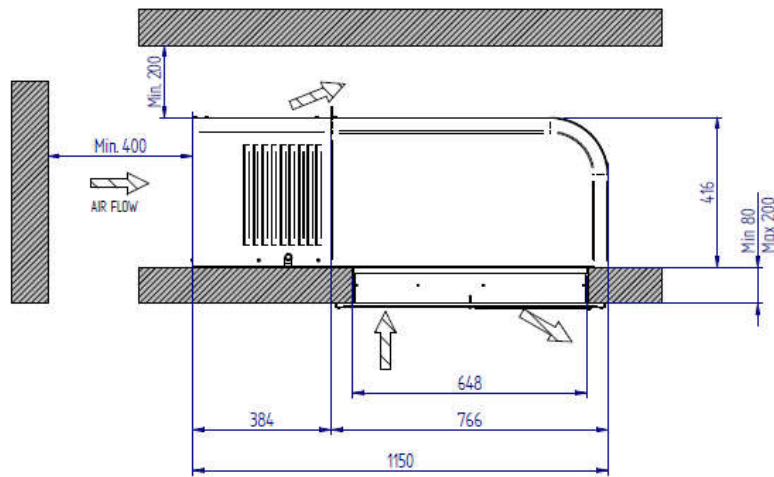
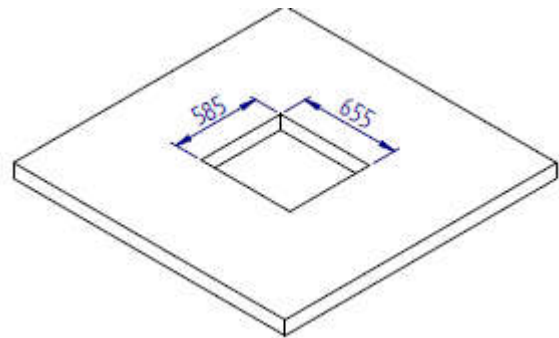
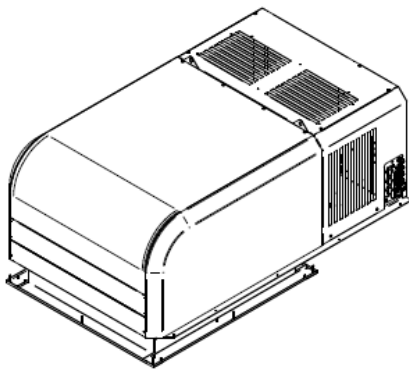
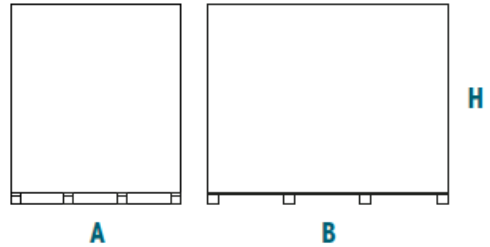

Figures and installation dimensions – Form CM230

FORM CM230

Packaging Dimensions:
A = 1.040 mm
B = 1.410 mm
H = 845 mm

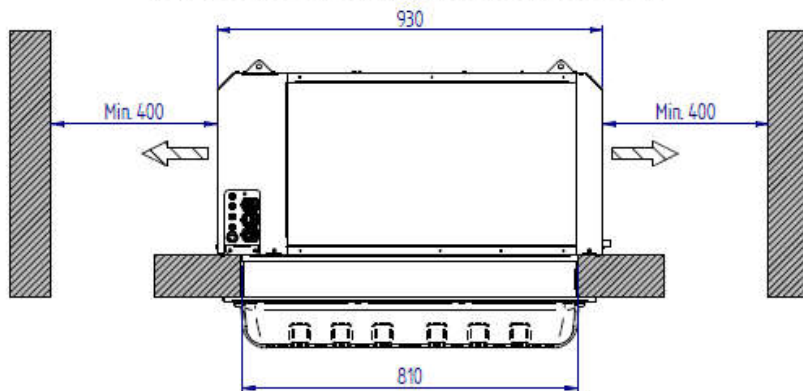
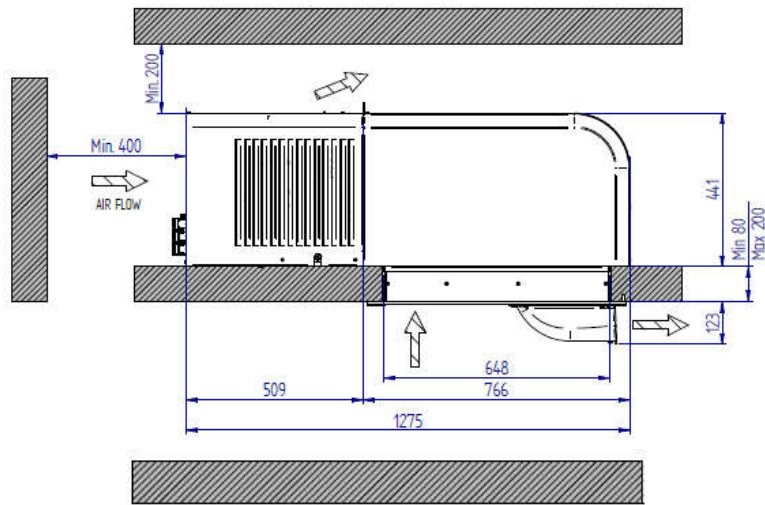
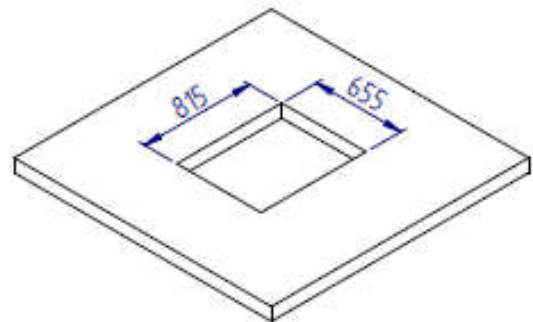
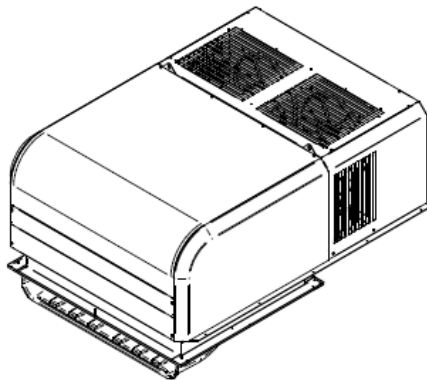
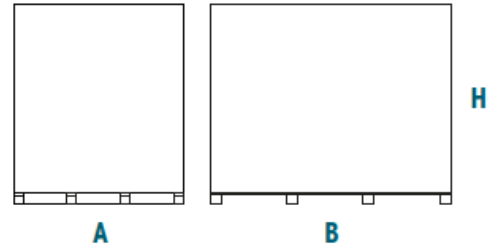

CELLBOX wall-mount chiller (KW) and freezer (TW) units – R452a

The CELLBOX BLOCK SYSTEMS consist of a ready-to-use condensation unit, a vaporizer, and an electronic temperature controller. They provide a simple solution for various refrigeration applications. They are available in different designs and deliver reliability due to accurate selection of components, our most stringent production and quality controls, and our long-time experience in refrigeration.

GENERAL TECHNICAL CHARACTERISTICS

- **Coolant: R452a**
- Self-supporting housing consisting of galvanised sheets, powder-coated
- Electronic temperature display and controller which - by means of an interface converter available as optional equipment - facilitate the connection to the ELIWELL TELEVIS / EWTD monitoring and remote maintenance system.
- Compressor (hermetic or semi-hermetic) with thermal coil protection
- CE approval
- Operating conditions: + 5 / + 43° C
- Winter and/or tropics controller optional
- Air-cooled condensers (water-cooled condensers are available upon request)
- Expansion by means of capillary tube, expansion valve optional
- Automatic defrosting programmable by means of controller
- Condensed water discharge directly into condensate evaporation bowl
- Heat exchanger with copper pipes and aluminium ribs

CELLBOX KW – Wall-Mount Units for Chilling – R452a**- 5 / + 5 °C**

Compact ready-to-use chilling unit for wall mounting
 Piggyback devices, can also be provided as slide-in devices upon request

Coolant: **R452 a****Standard equipment:**

- Electronic cooling controller
- Switch ON / OFF and light switch
- Power cord 2.5 m with plug. Fuse protection provided by customer
- Connection cable 2.5 m for door contact switch
- Lighting with 2.5 m cord
- Heated evaporation bowl for condensate
- High pressure switch
- For ambient temperature of up to 43°C

Refer to pages 6 – 7 for figures and dimensions

Type	CELLBOX KW 100	CELLBOX KW 200	CELLBOX KW 300	CELLBOX KW 400								
Form	A	A	B	B								
Electrical Parameters												
Voltage Volt/Ph/Hz	230 / 1 / 50	230 / 1 / 50	230 / 1 / 50	400 / 3 / 50								
Power consumption W	829	1083	1200	1286								
Current consumption A	5,2	5,3	5,8	3,0								
Compressor												
Type / output W	Fully hermetic – 370	Fully hermetic – 735	Fully hermetic – 826	Fully hermetic – 919								
Condenser												
Fan (diameter) mm	1 x 254	1 x 254	1 x 300	1 x 300								
Air quantity m ³ / h	683	657	1270	1206								
Vaporizer												
Fan (diameter) mm	1 x 200	1 x 200	2 x 200	2 x 200								
Air quantity m ³ / h	570	500	1030	900								
Air dispersion m	5	5	5	5								
Expansion	Capillary tube	Capillary tube	Capillary tube	Capillary tube								
Type of defrosting	Hot gas	Hot gas	Hot gas	Hot gas								
Weight net / gross (kg)	49 / 62	61 / 74	76 / 101	77 / 102								
Noise level¹⁾ db(A)	34	42,2	44,2	44,4								
Cooling output W												
Coldroom temperature °C	+5	0	-5	+5	0	-5	+5	0	-5	+5	0	-5
At +32° C outside temp.	1107	975	851	1621	1420	1229	2260	1960	1678	2604	2234	1890
At +43° C outside temp.	936	826	716	1390	1209	1041	1922	1664	1422	2209	1894	1597
Coldroom volume m³	All values based on 80mm PUR insulation thickness											
Coldroom temperature °C	+5	0	-5	+5	0	-5	+5	0	-5	+5	0	-5
At +32° C outside temp.	9,1	6,0	4,0	16,0	11,1	7,4	23,9	16,4	10,6	29,1	19,8	12,6
At +43° C outside temp.	6,0	4,2	3,3	10,8	7,1	6,2	17,7	11,3	8,7	21,8	13,6	10,4

Accessories:

- Water-cooled condenser
- Winter controller complete consisting of: ²⁾
 - Pressostatic speed controller
 - Oil sump heater
 - Low pressure switch
- Oil sump heater
- Low pressure switch
- Panel for slide-in device
- Assembly opening and/or recess

¹⁾ Measured in 10 m distance; variations possible depending on ambient conditions.²⁾ Winter control necessary at ambient temperatures of < +5°C. When mounted outside, unit must be roofed in.

CELLBOX KW – Wall-Mount Units for Chilling – R452a

- 5 / + 5 °C

Compact ready-to-use chilling unit for wall mounting
 Piggyback devices, can also be provided as slide-in devices upon request

Coolant: R452 a

Standard equipment:

- Electronic cooling controller
- Switch ON / OFF and light switch
- Power cord 2.5 m with plug. Fuse protection provided by customer
- Connection cable 2.5 m for door contact switch
- Lighting with 2.5 m cord
- Heated evaporation bowl for condensate
- High pressure switch
- For ambient temperature of up to 43°C

Refer to pages 7-8 for figures and dimensions

Type	CELLBOX KW 500	CELLBOX KW 600	CELLBOX KW 700						
Form	B	C	C						
Electrical Parameters									
Voltage Volt/Ph/Hz	400 / 3 / 50	400 / 3 / 50	400 / 3 / 50						
Power consumption W	1504	1540	1915						
Current consumption A	3.8	4.0	4.5						
Compressor									
Type / output W	Fully hermetic - 1100	Fully hermetic - 1470	Fully hermetic- 2200						
Condenser									
Fan (diameter) mm	1 x 300	1 x 350	1 x 350						
Air quantity m ³ / h	1206	2116	2035						
Vaporizer									
Fan (diameter) mm	2 x 200	1 x 350	1 x 350						
Air quantity m ³ / h	900	2050	1740						
Air dispersion m	5	8	8						
Expansion	Capillary tube	Capillary tube	Capillary tube						
Type of defrosting	Hot gas	Hot gas	Hot gas						
Weight net / gross (kg)	83 / 108	97 / 129	122 / 154						
Noise level¹⁾ db(A)	44,7	44,3	44,6						
Cooling output W									
Coldroom temperature °C	+5	0	-5	+5	0	-5	+5	0	-5
At +32° C outside temp.	2906	2527	2166	3541	2995	2562	3931	3389	2870
At +43° C outside temp.	2440	2116	1810	2865	2475	2106	3226	2767	2324
Coldroom volume m³	All values based on 80mm PUR insulation thickness								
Coldroom temperature °C	+5	0	-5	+5	0	-5	+5	0	-5
At +32° C outside temp.	34,2	23,9	15,4	42,1	31,1	20,2	49,1	37,6	24,7
At +43° C outside temp.	25,2	16,0	12,4	31,3	19,8	15,2	36,1	22,6	16,7

Accessories:

- Water-cooled condenser
- Winter controller complete consisting of: ²⁾
 - Pressostatic speed controller
 - Oil sump heater
 - Low pressure switch
- Oil sump heater
- Low pressure switch
- Panel for slide-in device
- Assembly opening and/or recess

¹⁾ Measured in 10 m distance; variations possible depending on ambient conditions.

²⁾ Winter control necessary at ambient temperatures of < +5°C. When mounted outside, unit must be roofed in.

CELLBOX TW – Wall-Mount Units for Freezing – R452a

-15 / -25 °C

Compact ready-to-use freezing unit for wall mounting
 Piggyback devices, can also be provided as slide-in devices upon request

Coolant: R452 a

Standard equipment:

- Electronic cooling controller
- Switch ON / OFF and light switch
- Power cord 2.5 m with plug. Fuse protection provided by customer
- Connection cable 2.5 m for door contact switch
- Lighting with 2.5 m cord
- Heated evaporation bowl for condensate
- High pressure switch
- Conn. cable 2.5 m for door frame heater
- For ambient temperature of up to 43°C

Refer to pages 6-7 for figures and dimensions

Type	CELLBOX TW 100	CELLBOX TW 200	CELLBOX TW 300						
Form	A	B	B						
Electrical Parameters									
Voltage Volt/Ph/Hz	230 / 1 / 50	230 / 1 / 50	400 / 3 / 50						
Power consumption W	999	1061	1422						
Current consumption A	5.4	5.6	3.2						
Compressor									
Type / output W	Fully hermetic - 1100	Fully hermetic - 1121	Fully hermetic – 1723						
Condenser									
Fan (diameter) mm	1 x 254	1 x 300	1 x 300						
Air quantity m ³ / h	657	1270	1206						
Vaporizer									
Fan (diameter) mm	1 x 200	2 x 200	2 x 200						
Air quantity m ³ / h	500	1030	900						
Air dispersion m	5	5	5						
Expansion	Expansion Valve	Expansion Valve	Expansion Valve						
Type of defrosting	Hot gas	Hot gas	Hot gas						
Weight net / gross (kg)	60 / 73	79 / 104	91 / 116						
Noise level¹⁾ db(A)	42,6	44,4	45,0						
Cooling output W									
Coldroom temp. °C	-15	-20	-25	-15	-20	-25	-15	-20	-25
At +32° C outside temp.	1137	953	780	1523	1265	1026	1910	1577	1269
At +43° C outside temp.	967	802	646	1257	1036	829	1618	1318	1039
Coldroom volume m³	All values based on 100mm PUR insulation thickness								
Coldroom temperature °C	-15	-20	-25	-15	-20	-25	-15	-20	-25
At +32° C outside temp.	10,8	6,1	3,7	21,7	11,1	6,0	25,8	16,3	9,5
At +43° C outside temp.	6,9	4,3	2,7	14,1	7,3	5,1	17,1	9,7	6,0

Accessories:

- Water-cooled condenser
- Winter controller complete consisting of: ²⁾
 - Pressostatic speed controller
 - Oil sump heater
 - Low pressure switch
- Oil sump heater
- Low pressure switch
- Panel for slide-in device
- Assembly opening and/or recess

¹⁾ Measured in 10 m distance; variations possible depending on ambient conditions.

²⁾ Winter control necessary at ambient temperatures of < +5°C. When mounted outside, unit must be roofed in.

CELLBOX TW – Wall-mount Units for Freezing – R452a

-15 / -25 °C

**Compact ready-to-use freezing unit for wall mounting
Piggyback devices, can also be provided as slide-in devices upon request**

Coolant: R452 a

Standard equipment:

- Electronic cooling controller
- Switch ON / OFF and light switch
- Power cord 2.5 m with plug. Fuse protection provided by customer
- Connection cable 2.5 m for door contact switch
- Lighting with 2.5 m cord
- Heated evaporation bowl for condensate
- High pressure switch
- Conn. cable 2.5 m for door frame heater
- For ambient temperature of up to 43°C

Refer to p. 8-9 for figures and dimensions

Type	CELLBOX TW 400	CELLBOX TW 500	CELLBOX TW 600						
Form	C	C	D						
Electrical Parameters									
Voltage Volt/Ph/Hz	400 / 3 / 50	400 / 3 / 50	400 / 3 / 50						
Power consumption W	1458	1777	2871						
Current consumption A	3.5	4.2	5.6						
Compressor									
Type / output W	Fully hermetic - 1470	Fully hermetic – 2200	Fully hermetic - 2940						
Condenser									
Fan (diameter) mm	1 x 350	1 x 350	2 x 300						
Air quantity m ³ / h	2116	2035	1900						
Vaporizer									
Fan (diameter) mm	1 x 350	1 x 350	2 x 315						
Air quantity m ³ / h	2050	1740	3109						
Air dispersion m	8	8	9						
Expansion	Expansion Valve	Expansion Valve	Expansion Valve						
Type of defrosting	Hot gas	Hot gas	Hot gas						
Weight net / gross (kg)	111 / 143	125 / 157	142 / 181						
Noise level¹⁾ db(A)	44,6	46,3	44,5						
Cooling output W									
Coldroom temperature °C	-15	-20	-25	-15	-20	-25	-15	-20	-25
At +32° C outside temp.	2314	1914	1543	2846	2343	1879	3633	2939	2309
At +43° C outside temp.	1938	1578	1243	2377	1936	1529	2991	2397	1854
Coldroom volume m³	All values based on 100mm PUR insulation thickness								
Coldroom temperature °C	-15	-20	-25	-15	-20	-25	-15	-20	-25
At +32° C outside temp.	1938	1578	1243	2377	1936	1529	2991	2397	1854
At +43° C outside temp.	22,6	16,4	7,3	35,0	27,0	11,8	40,3	30,8	20,2

Accessories:

- Water-cooled condenser
- Winter controller complete consisting of: ²⁾
 - Pressostatic speed controller
 - Oil sump heater
 - Low pressure switch
- Oil sump heater
- Low pressure switch
- Panel for slide-in device
- Assembly opening and/or recess

¹⁾ Measured in 10 m distance; variations possible depending on ambient conditions.

²⁾ Winter control necessary at ambient temperatures of < +5°C. When mounted outside, unit must be roofed in.

CELLBOX Wall-mount units (R452a) – Figures and Dimensions

FORM A Packaging dimensions W x L x H: 870 x 485 x 895 mm.

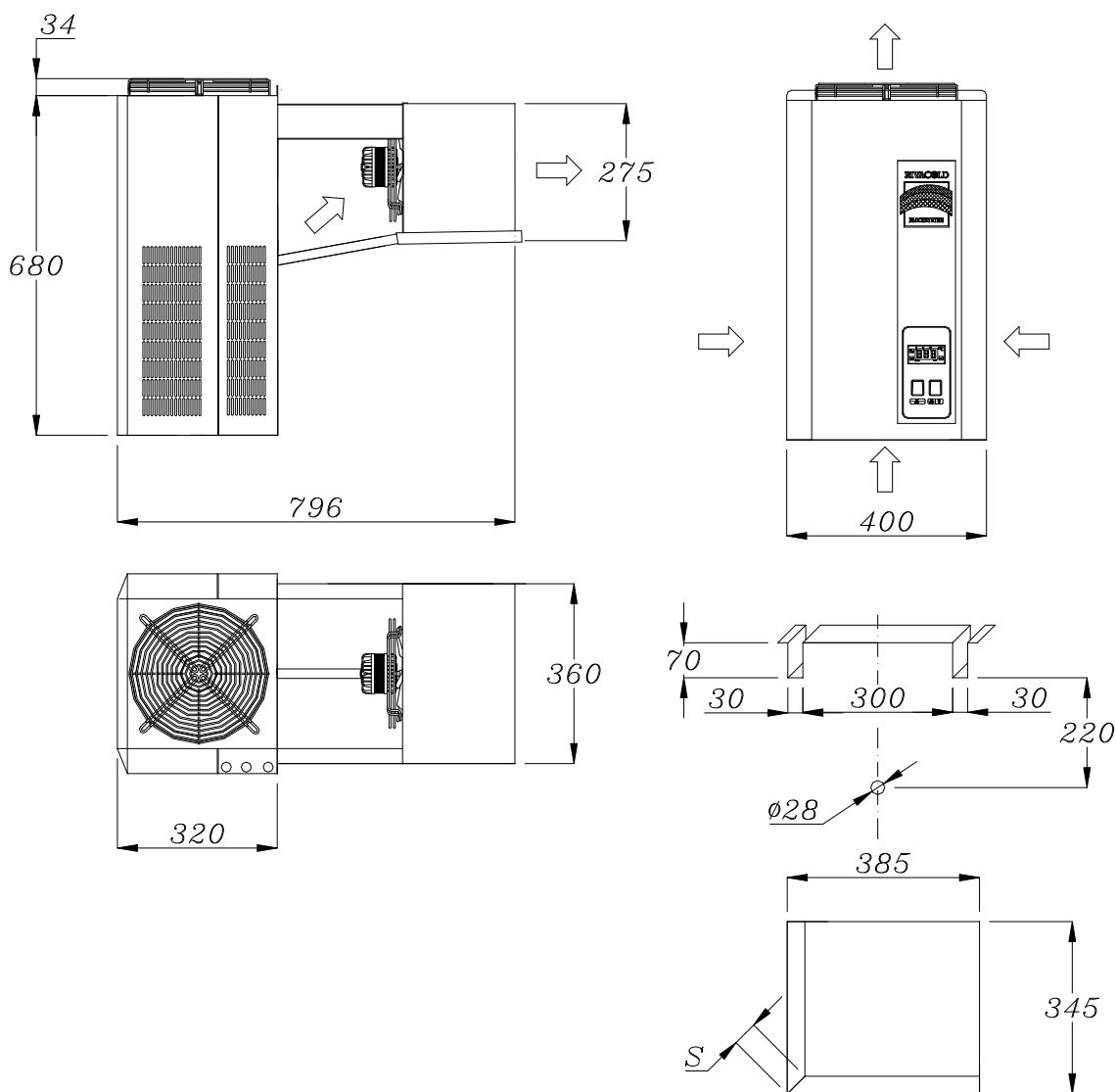

CELLBOX Wall-mount Units (R452a) – Figures and Dimensions

FORM B Packaging diemensions W x L x H: 785 x 1020 x 1025 mm.

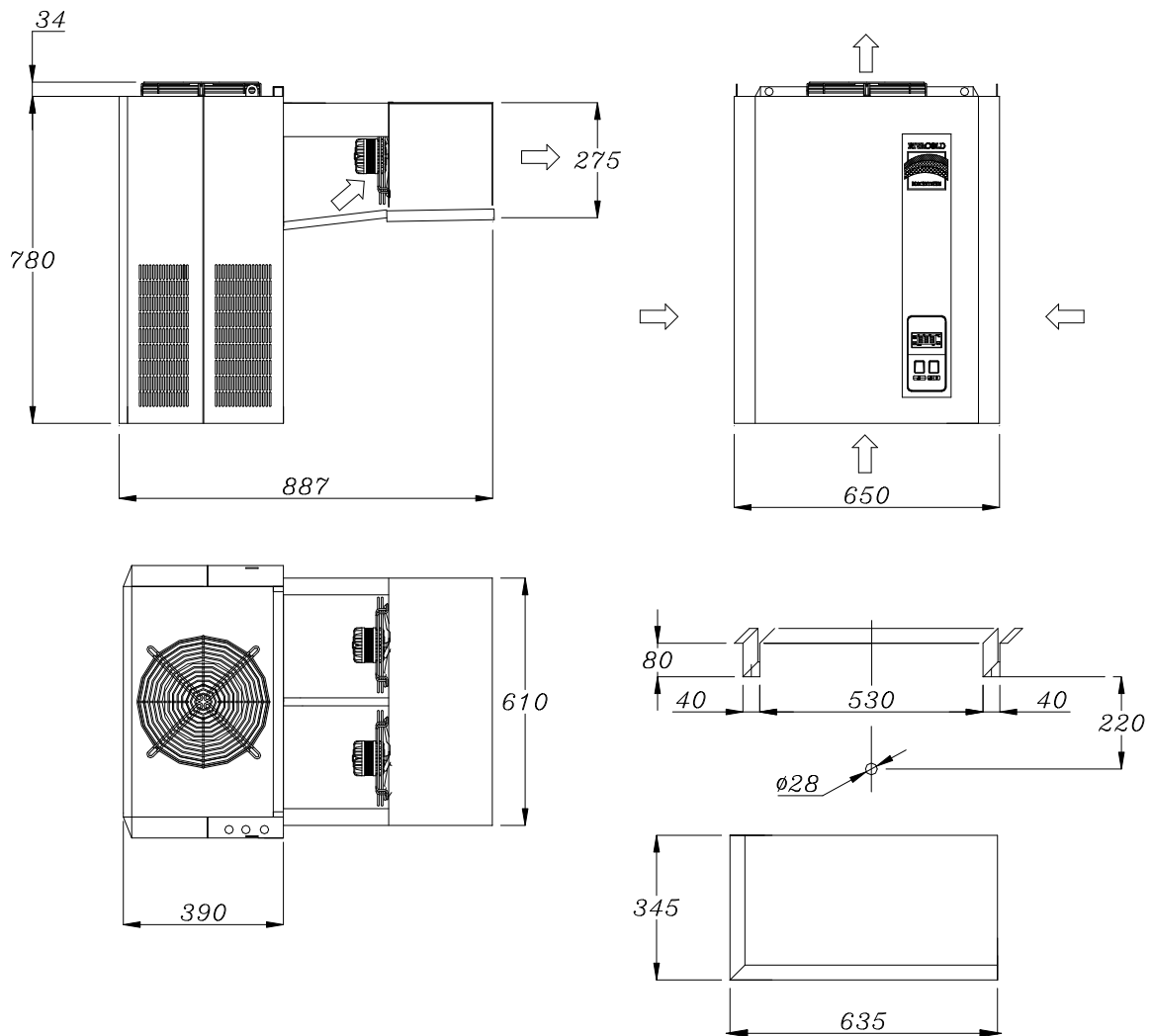

CELLBOX Wall-mount Units (R452a) – Figures and Dimensions

FORM C Packaging dimensions W x L x H: 835 x 1330 x 1065 mm.

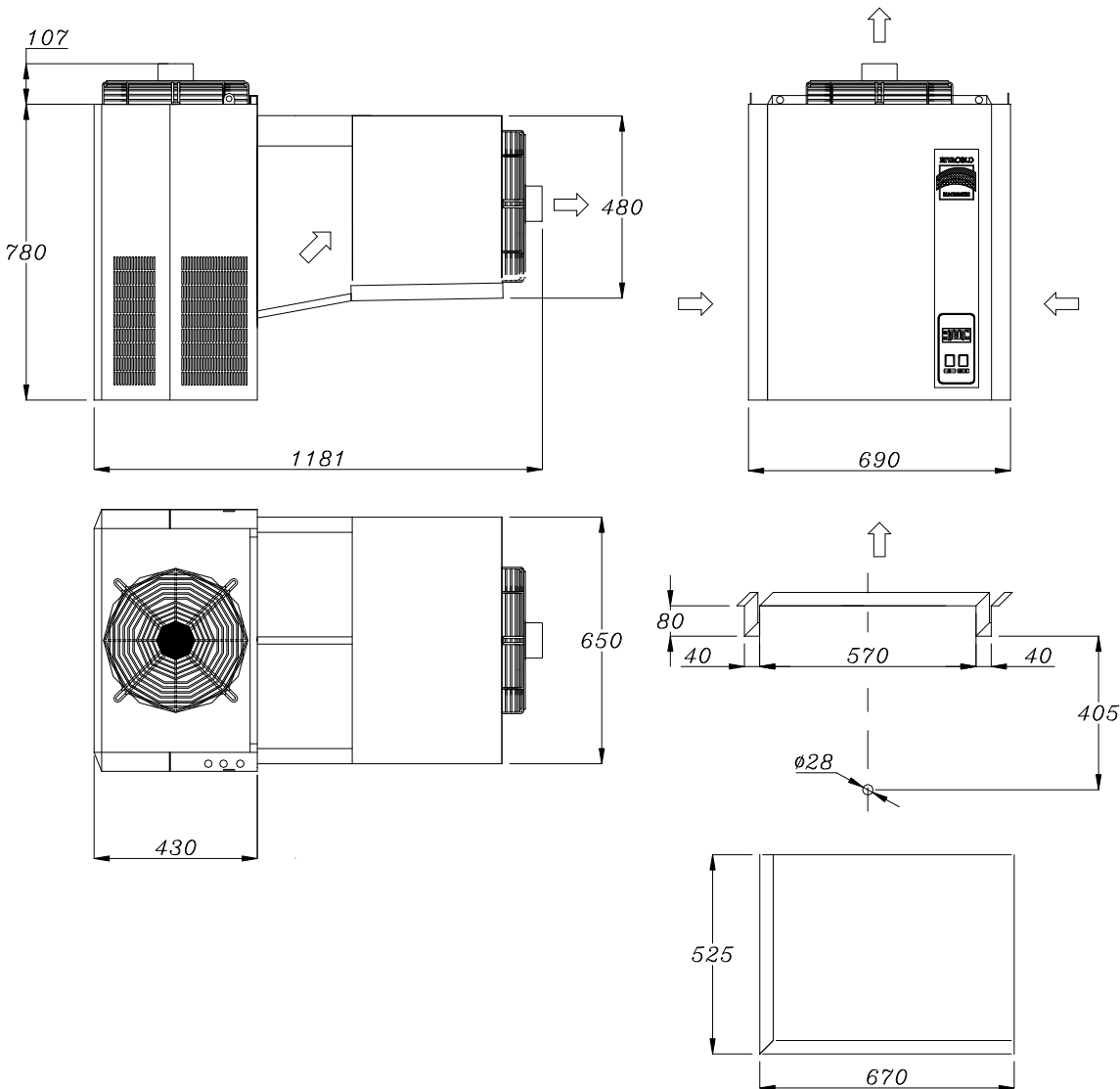

CELLBOX Wall-mount Units (R452a) – Figures and Dimensions

FORM D Packaging dimensions W x L x H: 1200 x 1192 x 980 mm

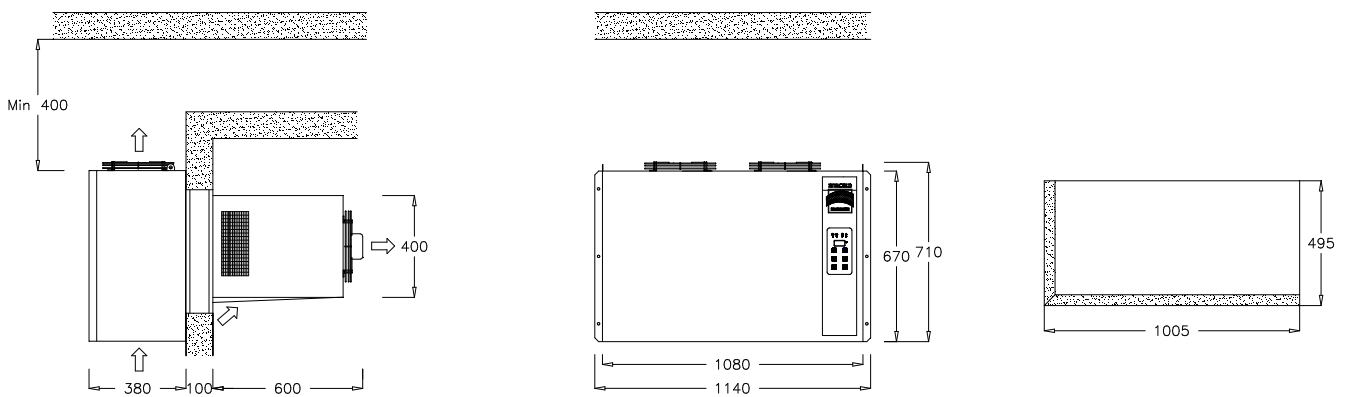

CELLBOX Roof-mount units for Chilling (KD) and Freezing (TD) – R452a

The CELLBOX BLOCK SYSTEMS consist of a ready-to-use condensation unit, a vaporizer, and an electronic temperature controller. They provide a simple solution for various refrigeration applications. They are available in different designs and deliver reliability due to accurate selection of components, our most stringent production and quality controls, and our long-time experience in refrigeration.

GENERAL TECHNICAL CHARACTERISTICS

- **Coolant: R452a**
- Self-supporting housing consisting of galvanised sheets, powder-coated
- Electronic temperature display and controller which - by means of an interface converter available as optional equipment - facilitate the connection to a monitoring and remote maintenance system
- Compressor (hermetic or semi-hermetic) with thermal coil protection
- CE approval
- Operating conditions: + 5 / + 43° C.
- Winter and/or tropics controller optional
- Air-cooled condensers (water-cooled condensers are available upon request)
- Expansion by means of capillary tube or expansion valve
- Automatic defrosting programmable by means of controller
- Condensed water discharge directly into condensate evaporation bowl
- Heat exchanger with copper pipes and aluminum ribs

CELLBOX KD – Roof-mount Units for Chilling – R452a

- 5 / + 5 °C

Compact ready-to-use chilling unit for ceiling mounting

Coolant: R452 a

Standard equipment:

- Electronic controller
- Remote control panel with 5 m connection cable
- Power cord 2.5 m with plug, fuse protection provided by customer
- Connection cable 2.5 m for door contact switch
- Lighting with 2.5 m cord
- Heated evaporation bowl for condensate
- High pressure switch
- For ambient temperature of up to 43°C

Refer to page 6 for figures and dimensions

Type	CELLBOX KD 100	CELLBOX KD 200	CELLBOX KD 300	CELLBOX KD 400								
Form	A	B	C	C								
Electrical Parameters												
Voltage Volt/Ph/Hz	230 / 1 / 50	230 / 1 / 50	230 / 1 / 50	230 / 1 / 50								
Power consumption W	539	814	1095	1280								
Current consumption A	3.2	4.9	5.8	6.2								
Compressor												
Type / output PS	Fully hermetic – 0.43	Fully hermetic – 0.5	Fully hermetic – 1.0	Fully hermetic – 1.12								
Condenser												
Fan (diameter) mm	1 x 254	1 x 300	2 x 254	2 x 254								
Air quantity m ³ / h	546	1053	1314	1314								
Vaporizer												
Fan (diameter) mm	1 x 200	1 x 200	2 x 200	2 x 200								
Air quantity m ³ / h	510	560	1020	960								
Air dispersion m	3	3	3.5	3.5								
Expansion	Capillary tube	Capillary tube	Capillary tube	Capillary tube								
Type of defrosting	Hot gas	Hot gas	Hot gas	Hot gas								
Weight net / gross (kg)	49 / 66	63 / 86	84 / 119	89 / 124								
Noise level ¹⁾ db(A)	32,5	44,0	41,7	45,1								
Cooling output W												
Coldroom temperature °C	+5	0	-5	+5	0	-5	+5	0	-5	+5	0	-5
At +32° C outside temp.	860	753	655	1218	1072	934	1870	1619	1385	2298	1996	1711
At +43° C outside temp.	710	622	540	1018	901	783	1557	1349	1154	1949	1692	1448
All values based on 80 mm PUR insulation												
Coldroom volume m³												
Coldroom temperature °C	+5	0	-5	+5	0	-5	+5	0	-5	+5	0	-5
At +32° C outside temp.	6,6	4,3	3,7	11,3	7,1	5,9	19,5	12,9	10,2	25,7	17,0	13,7
At +43° C outside temp.	5,0	3,3	2,8	8,1	5,3	4,4	14,3	9,4	7,4	19,2	12,7	10,2

Accessories:

- Water-cooled condenser
- Oil sump heater
- Winter controller complete consisting of: ²⁾
 - Pressostatic speed controller
 - Oil sump heater
 - Low pressure switch
- Low pressure switch
- Assembly opening and/or recess
- Expansion valve

¹⁾ Measured in 10 m distance; variations possible depending on ambient conditions.

²⁾ Winter control necessary at ambient temperatures of < +5°C. When mounted outside, unit must be roofed in.

CELLBOX KD – Roof-mount Units for Chilling – R452a

- 5 / + 5 °C

Compact ready-to-use chilling unit for ceiling mounting

Coolant: R452 a

Standard equipment:

- Electronic controller
- Remote control panel with 5 m connection cable
- Power cord 2.5m w. plug, fuse protection provided by customer
- Connection cable 2.5m for door contact switch
- Lighting with 2.5 m cord
- Heated evaporation bowl for condensate
- High pressure switch
- For ambient temperature of up to 43°C

Refer to page 7 for figures and dimensions

Type	CELLBOX KD 500	CELLBOX KD 600				
Form	D	D				
Electrical Parameters						
Voltage Volt/Ph/Hz	400 / 3 / 50	400 / 3 / 50				
Power consumption W	1428	1646				
Current consumption A	3.6	4.4				
Compressor						
Type / output PS	Fully hermetic – 1.25	Fully hermetic – 2.0				
Condenser						
Fan (diameter) mm	2 x 300	2 x 300				
Air quantity m ³ / h	2500	2281				
Vaporizer						
Fan (diameter) mm	3 x 200	3 x 200				
Air quantity m ³ / h	1480	1390				
Air dispersion m	4	4				
Expansion	Capillary tube	Capillary tube				
Type of defrosting	Hot gas	Hot gas				
Weight net / gross (kg)	90 / 127	110 / 147				
Noise level ¹⁾ db(A)	47,2	47,4				
Cooling output W						
Coldroom temperature °C	+5	0	-5	+5	0	-5
At +32° C outside temp.	2851	2442	2060	3415	2961	2531
At +43° C outside temp.	2398	2051	1725	2846	2456	2088
Coldroom volume m³	All values based on 80 mm PUR insulation					
Coldroom temperature °C	+5	0	-5	+5	0	-5
At +32° C outside temp.	33,8	21,9	17,2	42,8	28,2	22,5
At +43° C outside temp.	25,0	16,2	12,8	31,4	20,5	16,2

Accessories:

- Water-cooled condenser
- Winter controller complete consisting of: ²⁾
 - Pressostatic speed controller
 - Oil sump heater
 - Low pressure switch
- Oil sump heater
- Low pressure switch
- Assembly opening and/or recess

¹⁾ Measured in 10 m distance; variations possible depending on ambient conditions.

²⁾ Winter control necessary at ambient temperatures of < +5°C. When mounted outside, unit must be roofed in.

CELLBOX TD – Roof-mount Units for Freezing – R452a**-15 / -25 °C**

Compact ready-to-use freezing unit for ceiling mounting

Coolant: **R452a****Standard equipment:**

- Electronic controller
- Remote control panel with 5 m connection cable
- Power cord 2.5 m with plug, fuse protection provided by customer
- Connection cable 2.5 m for door contact switch
- Lighting with 2.5 m cord
- Heated evaporation bowl for condensate
- High pressure switch
- For ambient temperature of up to 43°C

Refer to page 6 for figures and dimensions

Type	CELLBOX TD 100	CELLBOX TD 200	CELLBOX TD 300						
Form	A	B	C						
Electrical Parameters									
Voltage Volt/Ph/Hz	230 / 1 / 50	230 / 1 / 50	230 / 1 / 50						
Power consumption W	598	786	1127						
Current consumption A	2.9	3.8	6.4						
Compressor									
Type / output PS	Fully hermetic – 0.75	Fully hermetic – 1.0	Fully hermetic – 1.5						
Condenser									
Fan (diameter) mm	1 x 254	1 x 300	2 x 254						
Air quantity m ³ / h	546	1053	1314						
Vaporizer									
Fan (diameter) mm	1 x 200	1 x 220	2 x 200						
Air quantity m ³ / h	510	560	960						
Air dispersion m	3	3	3,5						
Expansion	Expansion valve	Expansion valve	Expansion valve						
Type of defrosting	Hot gas	Hot gas	Hot gas						
Weight net / gross (kg)	52 / 69	54 / 77	90 / 125						
Noise level¹⁾ db(A)	32,4	44,1	42,2						
Cooling output W									
Coldroom temperature °C	-15	-20	-25	-15	-20	-25	-15	-20	-25
At +32° C outside temp.	693	586	486	1068	895	734	1523	1268	1030
At +43° C outside temp.	582	493	408	889	734	589	1257	1041	836
Coldroom volume m³	All values based on PUR 100 mm insulation thickness								
Coldroom temperature °C	-15	-20	-25	-15	-20	-25	-15	-20	-25
At +32° C outside temp.	3,5	2,8	1,8	7,3	5,7	3,8	13,0	10,4	6,8
At +43° C outside temp.	2,5	2,0	1,4	5,2	4,0	2,6	9,1	7,3	4,6

Accessories:

- Water-cooled condenser
- Winter controller complete consisting of: ²⁾
 - Pressostatic speed controller
 - Oil sump heater
 - Low pressure switch
- Oil sump heater
- Low pressure switch
- Assembly opening and/or recess

¹⁾ Measured in 10 m distance; variations possible depending on ambient conditions.²⁾ Winter control necessary at ambient temperatures of < +5°C. When mounted outside, unit must be roofed in.

CELLBOX TD – Roof-mount Units for Freezing – R452a

-15 / -25 °C

Compact ready-to-use freezing unit for roof mounting

Coolant: R452a

Standard equipment:

- Electronic controller
- Remote control panel with 5 m connection cable
- Power cord 2.5 m with plug, fuse protection provided by customer
- Connection cable 2.5 m for door contact switch
- Lighting with 2.5 m cord
- Evaporation bowl for condensate heated
- High pressure switch
- For ambient temperature of up to 43°C

Refer to page 7 for figures and dimensions

Type	CELLBOX TD 400	CELLBOX TD 500	CELLBOX TD 600						
Form	D	E	E						
Electrical Parameters									
Voltage Volt/Ph/Hz	400 / 3 / 50	400 / 3 / 50	400 / 3 / 50						
Power consumption W	1288	2084	2882						
Current consumption A	3.5	5.8	6.9						
Compressor									
Type / output PS	Fully hermetic – 2.0	Fully hermetic – 3.0	Fully hermetic – 4.0						
Condenser									
Fan (diameter) mm	2 x 300	2 x 350	2 x 350						
Air quantity m ³ / h	2500	4287	3825						
Vaporizer									
Fan (diameter) mm	3 x 200	3 x 300	3 x 300						
Air quantity m ³ / h	1480	2200	2100						
Air dispersion m	4	5	5						
Expansion	Expansion valve	Expansion valve	Expansion valve						
Type of defrosting	Hot gas	Hot gas	Hot gas						
Weight net / gross (kg)	119 / 156	179 / 233	192 / 246						
Noise level¹⁾ db(A)	47,5	46,9	47,8						
Cooling output W									
Coldroom temperature °C	-15	-20	-25	-15	-20	-25	-15	-20	-25
At +32° C outside temp.	2103	1733	1395	3302	2772	2276	4220	3560	2949
At +43° C outside temp.	1736	1417	1124	2684	2244	1828	3471	2924	2415
Coldroom volume m³	All values based on PUR 100 mm insulation thickness								
Coldroom temperature °C	-15	-20	-25	-15	-20	-25	-15	-20	-25
At +32° C outside temp.	22,2	17,3	11,1	44,7	36,4	24,2	65,2	52,7	35,7
At +43° C outside temp.	15,7	12,1	7,6	31,1	25,1	16,9	46,1	34,9	25,6

Accessories:

- Water-cooled condenser
- Winter controller complete consisting of: ²⁾
 - Pressostatic speed controller
 - Oil sump heater
 - Low pressure switch
- Oil sump heater
- Low pressure switch
- Assembly opening and/or recess

¹⁾ Measured in 10 m distance; variations possible depending on ambient conditions.

²⁾ Winter control necessary at ambient temperatures of < +5°C. When mounted outside, unit must be roofed in.

CELLBOX Roof-mount Units (R452a) – Figures and Dimensions

FORM A Packaging dimensions W x L x H: 920 x 600 x 661 mm

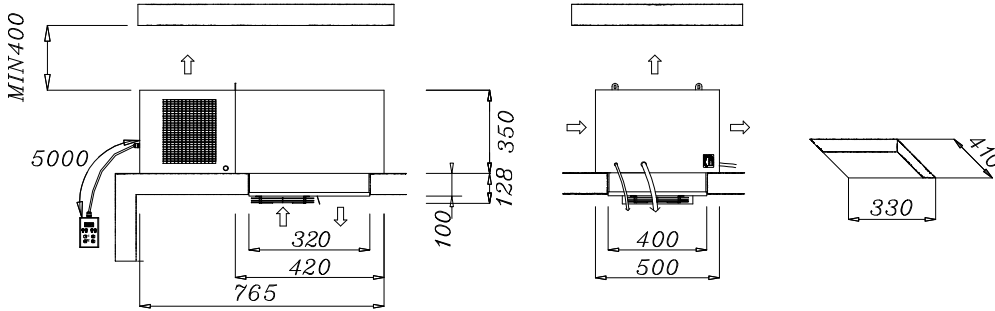

FORM B Packaging dimensions W x L x H: 990 x 800 x 700 mm

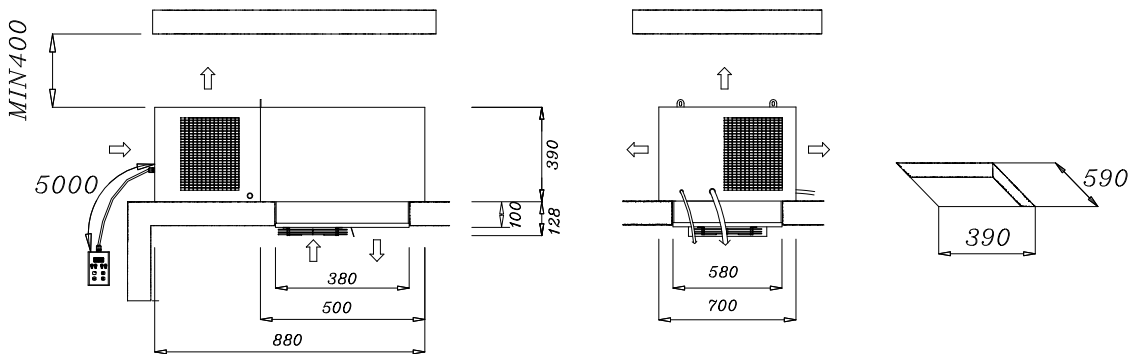

FORM C Packaging dimensions W x L x H: 1050 x 1250 x 806 mm

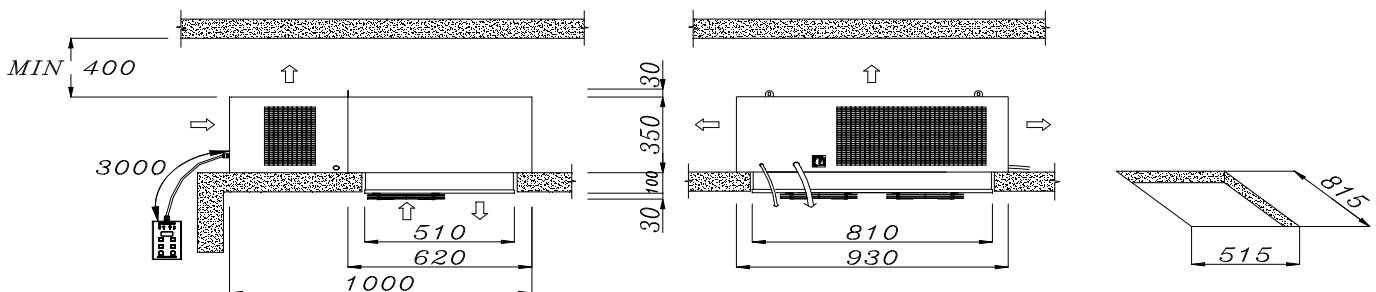

CELLBOX Roof-mount Units (R452a) – Figures and Dimensions

FORM D Packaging dimensions W x L x H: 1050 x 1250 x 806 mm

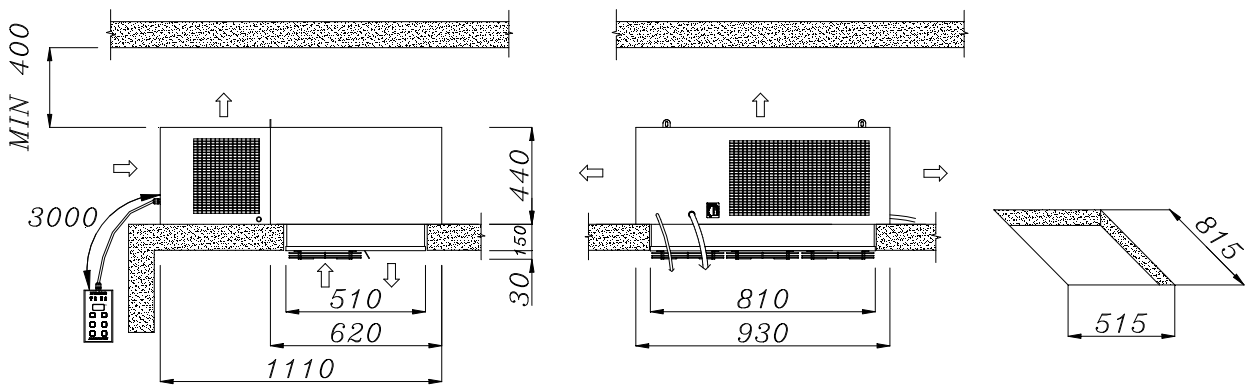

FORM E Packaging dimensions W x L x H: 1420 x 1460 x 876 mm

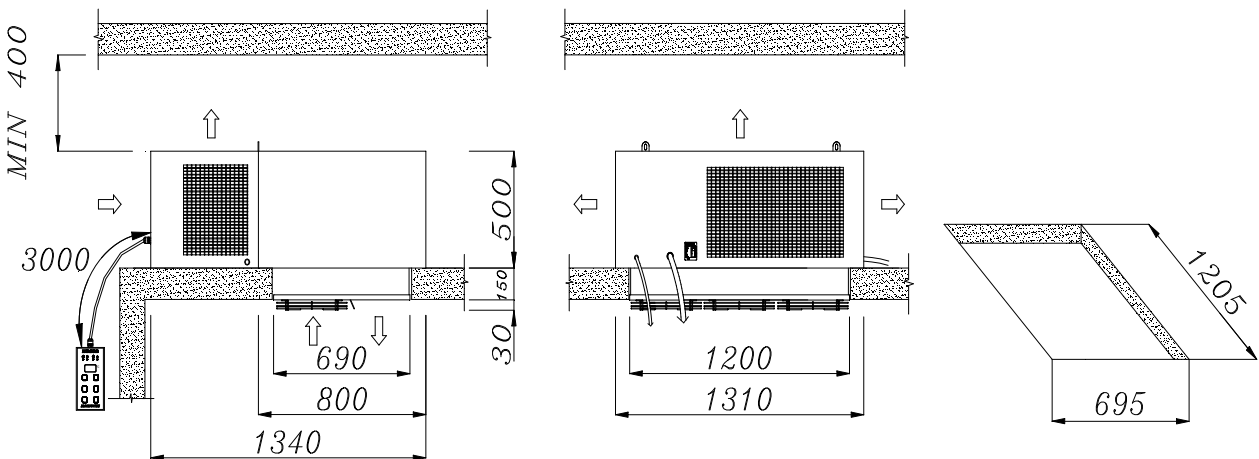

CELLBOX Split-Units for Chilling (KS) and Freezing (TS) – R452a



for refrigeration of coldrooms

The CELLBOX BLOCK SYSTEMS consist of a ready-to-use condensation unit, a vaporizer, and an electronic temperature controller. They provide a simple solution for various refrigeration applications. They are available in different designs and deliver reliability due to accurate selection of components, our most stringent production and quality controls, and our long-time experience in refrigeration.

GENERAL TECHNICAL CHARACTERISTICS

- **Coolant: R452a**
- Self-supporting housing consisting of galvanized sheets, powder-coated
- Electronic temperature display and controller which - by means of an interface converter available as optional equipment - facilitate the connection to the a monitoring and remote maintenance system.
- Compressor (hermetic or semi-hermetic) with thermal coil protection
- CE approval
- Operating conditions: + 5 / + 43° C.
- Winter and/or tropics controller optional
- Air-cooled condensers (water-cooled condensers are available upon request)
- Expansion by means of capillary tube or expansion valve
- Automatic defrosting programmable by means of controller
- Heat exchanger with copper pipes and aluminium ribs

CELLBOX KS – Split-Unit for Chilling - R452a

- 5 / + 5 °C

Compact chilling unit as split device

Coolant: R452a

Standard equipment:

- For ambient temperature of up to 43°C
- Pre-filled coolant lines 5 m
- Electronic controller
- Remote control panel: connection length corresponds to cooling line
- Door contact switch: connection length corresponds to cooling line
- Lighting, cord length corresp. to cooling line
- Connection for pre-filled coolant lines
- High pressure switch
- Condensate discharge connection to the outside (with heater, without pipeline)
- Power cord 2.5 m with plug, fuse protection provided by customer

Refer to pages 6-7 for figures and dimensions

Type	CELLBOX KS 100	CELLBOX KS 200	CELLBOX KS 300	CELLBOX KS 400								
Form	Aa	Ab	Ba	Bb								
Electrical Parameters												
Voltage Volt/Ph/Hz	230 / 1 / 50	230 / 1 / 50	230 / 1 / 50	400 / 3 / 50								
Power consumption W	829	1145	1200	1292								
Current consumption A	5.2	5.6	5.8	3.4								
Compressor												
Type / output W	Fully hermetic - 370	Fully hermetic - 740	Fully hermetic - 880	Fully hermetic - 920								
Condenser												
Fan (diameter) mm	1 x 254	1 x 254	1 x 300	1 x 300								
Air quantity m ³ / h	683	657	1270	1206								
Vaporizer												
Fan (diameter) mm	1 x 200	2 x 200	2 x 200	2 x 250								
Air quantity m ³ / h	600	1213	1170	1602								
Air dispersion m	3	3.5	3.5	3.5								
Expansion	Capillary tube	Capillary tube	Capillary tube	Expansion valve								
Type of defrosting	Electrical	Electrical	Electrical	Electrical								
Weight net / gross (kg)	58 / 69	61 / 79	78 / 97	85 / 105								
Noise level ¹⁾ db(A)	34,0	42,2	44,2	44,4								
Cooling output W												
Coldroom temp. °C	+5	0	-5	+5	0	-5	+5	0	-5	+5	0	-5
At +32° C outside temp.	1112	979	855	1711	1501	1301	2226	1932	1656	2522	2165	1833
At +43° C outside temp.	939	829	719	1458	1269	1092	1895	1641	1403	2140	1834	1545
Coldroom volume m³					All values based on PUR 80 mm insulation thickness							
Coldroom temperature °C	+5	0	-5	+5	0	-5	+5	0	-5	+5	0	-5
At +32° C outside temp.	9,1	6,0	4,0	17,0	11,9	7,9	23,7	16,3	10,5	28,1	19,1	12,1
At +43° C outside temp.	6,1	4,2	3,4	11,7	7,6	6,5	17,1	11,0	8,5	21,0	13,1	9,9

Accessories:

- Water-cooled condenser
- Winter controller complete consisting of: ²⁾
 - Pressostatic speed controller
 - Oil sump heater
 - Low pressure switch
- Oil sump heater
- Expansion valve (standard for KS 400)
- Pre-filled coolant lines 10 m
- Pre-filled coolant lines 15 m

¹⁾ Measured in 10 m distance; variations possible depending on ambient conditions.

²⁾ Winter control necessary at ambient temperatures of < +5°C. When mounted outside, unit must be roofed in.

³⁾ As for the scope of installation, please notice description on page 9.

CELLBOX KS – Split-Unit for Chilling – R452a

- 5 / + 5 °C

Compact chilling unit as split device

Coolant: R452a

Standard equipment:

- For ambient temperature of up to 43°C
- Pre-filled coolant lines 5 m
- Electronic controller
- Remote control panel: connection length corresponds to cooling line
- Door contact switch: connection length corresponds to cooling line
- Lighting, cord length corresp. to cooling line
- Connection for pre-filled coolant lines
- High pressure switch
- Condensate discharge connection to the outside (with heater, without pipeline)
- Power cord 2.5 m with plug, fuse protection provided by customer

Refer to page 8 for figures and dimensions

Type	CELLBOX KS 500	CELLBOX KS 600	CELLBOX KS 700						
Form	Bc	C	C						
Electrical Parameters									
Voltage Volt/Ph/Hz	400 / 3 / 50	400 / 3 / 50	400 / 3 / 50						
Power consumption W	1525	1615	1990						
Current consumption A	4.6	4.8	5.3						
Compressor									
Type / output W	Fully hermetic - 1100	Fully hermetic - 1100	Fully hermetic - 1470						
Condenser									
Fan (diameter) mm	1 x 300	1 x 350	1 x 350						
Air quantity m ³ / h	1206	2116	2035						
Vaporizer									
Fan (diameter) mm	3 x 254	3 x 254	3 x 254						
Air quantity m ³ / h	2364	2364	2167						
Air dispersion m	7,5	7,5	7						
Expansion	Expansion valve	Expansion valve	Expansion valve						
Type of defrosting	Electrical	Electrical	Electrical						
Weight net / gross (kg)	92 / 114	102 / 125	113 / 136						
Noise level¹⁾ db(A)	44,7	44,6	44,6						
Cooling output W									
Coldroom temp. °C	+5	0	-5	+5	0	-5	+5	0	-5
At +32° C outside temp.	3099	2703	2323	3264	2833	2423	3809	3281	2778
At +43° C outside temp.	2564	2227	1906	2723	2352	2001	3136	2687	2255
Coldroom volume m³	All values based on PUR 80 mm insulation thickness								
Coldroom temperature °C	+5	0	-5	+5	0	-5	+5	0	-5
At +32° C outside temp.	37,1	26,0	16,8	39,6	27,6	17,8	47,1	36,1	23,5
At +43° C outside temp.	27,3	17,3	13,3	29,6	18,6	14,2	35,0	20,5	16,4

Accessories:

- Water-cooled condenser
- Oil sump heater
- Winter controller complete consisting of: ²⁾
 - Pressostatic speed controller
 - Oil sump heater
 - Low pressure switch
- Pre-filled coolant lines 10 m
- Pre-filled coolant lines 15 m

¹⁾ Measured in 10 m distance; variations possible depending on ambient conditions.

²⁾ Winter control necessary at ambient temperatures of < +5°C. When mounted outside, unit must be roofed in.

³⁾ As for the scope of installation, please notice description on page 9.

CELLBOX TS - Split-Unit for Freezing - R452a**-15 / -25 °C**

Compact freezing unit as split device

Coolant: **R452a****Standard equipment:**

- For ambient temperature of up to 43°C
- Pre-filled coolant lines 5 m
- Electronic controller
- Remote control panel: connection length corresponds to cooling line
- Door contact switch: connection length corresponds to cooling line
- Lighting, cord length corresp. to cooling line
- Connection for pre-filled coolant lines
- High pressure switch
- Condensate discharge connection to the outside (with heater, without pipeline)
- Power cord 2.5 m with plug, fuse protection provided by customer

Refer to pages 6-7 for figures and dimensions

Type	CELLBOX TS 100	CELLBOX TS 200	CELLBOX TS 300	CELLBOX TS 400								
Form	Aa	Aa	Ab	Bb								
Electrical Parameters												
Voltage Volt/Ph/Hz	230 / 1 / 50	230 / 1 / 50	230 / 1 / 50	230 / 1 / 50								
Power consumption W	602	786	1061	1067								
Current consumption A	3.4	3.8	5.7	6.0								
Compressor												
Type / output W	Fully hermetic – 740	Fully hermetic – 740	Fully hermetic - 1100	Fully hermetic - 1100								
Condenser												
Fan (diameter) mm	1 x 254	1 x 254	1 x 254	1 x 300								
Air quantity m ³ / h	630	657	657	1270								
Vaporizer												
Fan (diameter) mm	1 x 200	1 x 200	2 x 200	2 x 254								
Air quantity m ³ / h	630	600	1230	1602								
Air dispersion m	3	3	3.5	7.5								
Expansion	Expansion Valve	Expansion Valve	Expansion Valve	Expansion Valve								
Type of defrosting	Electric	Electric	Electric	Electric								
Weight net / gross (kg)	58 / 74	62 / 78	66 / 84	78 / 98								
Noise level¹⁾ db(A)	33,8	42,1	42,6	44,4								
Cooling output W												
Coldroom temperature °C	-15	-20	-25	-15	-20	-25	-15	-20	-25	-15	-20	-25
At +32° C outside temp.	734	624	522	963	808	663	1221	1028	845	1522	1264	1025
At +43° C outside temp.	612	519	431	806	665	533	1029	857	692	1253	1033	826
Coldroom volume m³	All values based on PUR 100 mm insulation thickness											
Coldroom temperature °C	-15	-20	-25	-15	-20	-25	-15	-20	-25	-15	-20	-25
At +32° C outside temp.	5,6	3,3	1,9	8,5	5,0	2,7	13,1	7,3	4,1	21,3	11,5	6,6
At +43° C outside temp.	3,4	2,2	1,3	5,4	3,1	2,0	10,1	5,4	3,6	13,9	7,5	5,1

Accessories:

- Water-cooled condenser
- Signal amplifier for remote control panel >10m
- Winter controller complete consisting of:²⁾
 - Pressostatic speed controller
 - Oil sump heater
 - Low pressure switch
- Oil sump heater
- Low pressure switch
- Pre-filled coolant lines 10 m
- Pre-filled coolant lines 15 m

¹⁾ Measured in 10 m distance; variations possible depending on ambient conditions.²⁾ Winter control necessary at ambient temperatures of < +5°C. When mounted outside, unit must be roofed in.³⁾ As for the scope of installation, please notice description on page 9.

CELLBOX TS – Split-Units for Freezing – R452a

-15 / -25 °C

Compact freezing unit as split device

Coolant: R452a

Standard equipment:

- For ambient temperature of up to 43°C
- Pre-filled coolant lines 5 m
- Electronic controller
- Remote control panel: connection length corresponds to cooling line
- Door contact switch: connection length corresponds to cooling line
- Lighting, cord length corresp. to cooling line
- Connection for pre-filled coolant lines
- High pressure switch
- Condensate discharge connection to the outside (with heater, without pipeline)
- Power cord 2.5 m with plug, fuse protection provided by customer

Refer to page 7-8 for figures and dimensions

Type	CELLBOX TS 500	CELLBOX TS 600	CELLBOX TS 700						
Form	Bb	C	C						
Electrical Parameters									
Voltage Volt/Ph/Hz	400 / 3 / 50	400 / 3 / 50	400 / 3 / 50						
Power consumption W	1428	1533	1852						
Current consumption A	3.6	4.3	5.0						
Compressor									
Type / output PS	Fully hermetic - 1470	Fully hermetic - 1470	Fully hermetic - 2200						
Condenser									
Fan (diameter) mm	1 x 300	1 x 350	1 x 350						
Air quantity m ³ / h	1206	2116	2035						
Vaporizer									
Fan (diameter) mm	2 x 254	3 x 254	3 x 254						
Air quantity m ³ / h	1602	2364	2364						
Air dispersion m	7.5	7.5	7.5						
Expansion	Expansion Valve	Expansion Valve	Expansion Valve						
Type of defrosting	Electric	Electric	Electric						
Weight net / gross (kg)	89 / 109	111 / 134	111 / 134						
Noise level¹⁾ db(A)	45,0	44,6	46,3						
Cooling output W									
Coldroom temperature °C	-15	-20	-25	-15	-20	-25	-15	-20	-25
At +32° C outside temp.	1875	1553	1254	2187	1809	1458	2599	2144	1725
At +43° C outside temp.	1582	1290	1018	1834	1492	1174	2174	1770	1397
Coldroom volume m³	All values based on PUR 100 mm insulation thickness								
Coldroom temperature °C	-15	-20	-25	-15	-20	-25	-15	-20	-25
At +32° C outside temp.	24,7	15,3	8,9	27,3	16,5	9,3	43,7	25,4	14,1
At +43° C outside temp.	17,5	9,7	6,0	21,9	12,8	7,3	32,3	24,3	11,0

Accessories:

- Water-cooled condenser
- Oil sump heater
- Winter controller complete consisting of: ²⁾
 - Pressostatic speed controller
 - Oil sump heater
 - Low pressure switch
- Low pressure switch
- Pre-filled coolant lines 10 m
- Pre-filled coolant lines 15 m

¹⁾ Measured in 10 m distance; variations possible depending on ambient conditions.

²⁾ Winter control necessary at ambient temperatures of < +5°C. When mounted outside, unit must be roofed in.

³⁾ As for the scope of installation, please notice description on page 9.

CELLBOX Split-Units (R452a) – Figures and Dimensions

FORM Aa Packaging dimensions WxLxH : 800 x 600 x 1120 mm

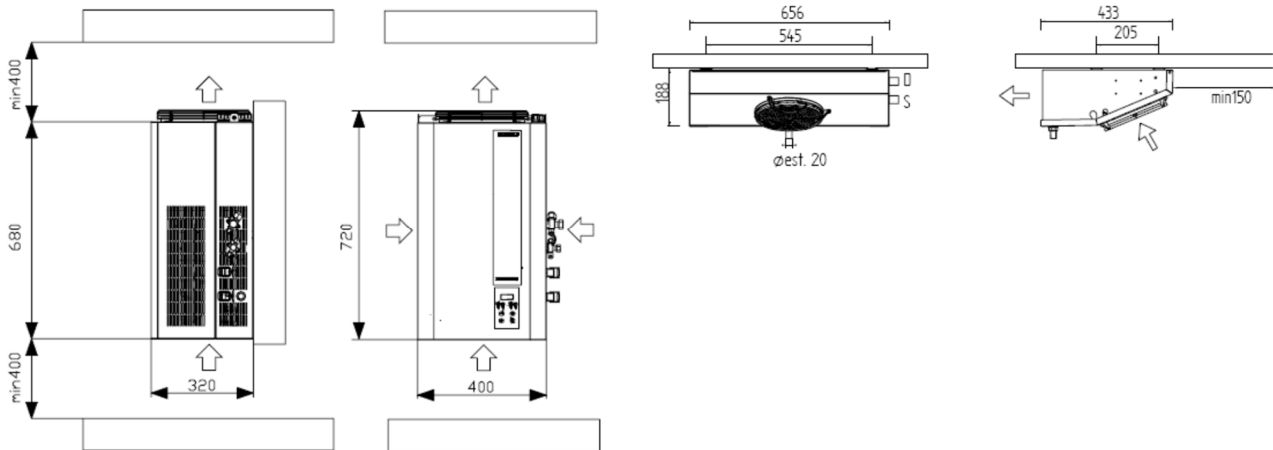

FORM Ab Packaging dimensions WxLxH: 1240 x 600 x 1120 mm

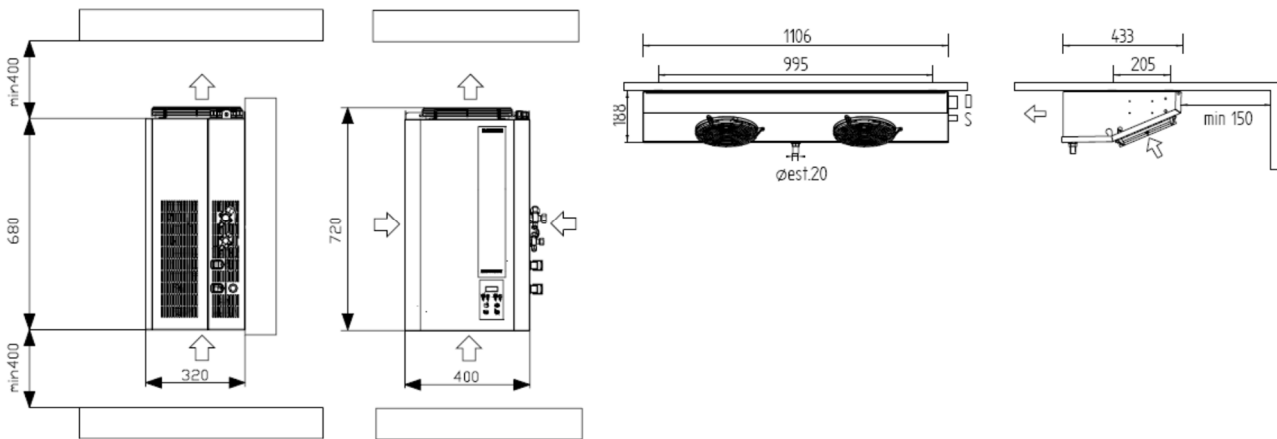

CELLBOX Split-Units (R452a) – Figures and Dimensions

FORM Ba Packaging dimensions WxLxH: 1240 x 600 x 1425 mm

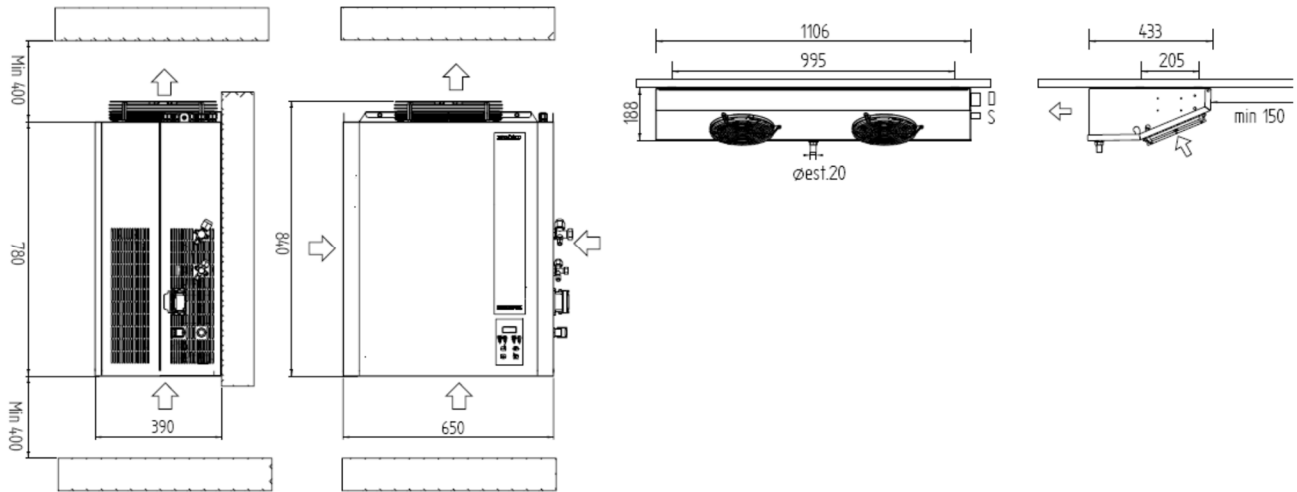

FORM Bb Packaging dimensions WxLxH: 1240 x 600 x 1425 mm

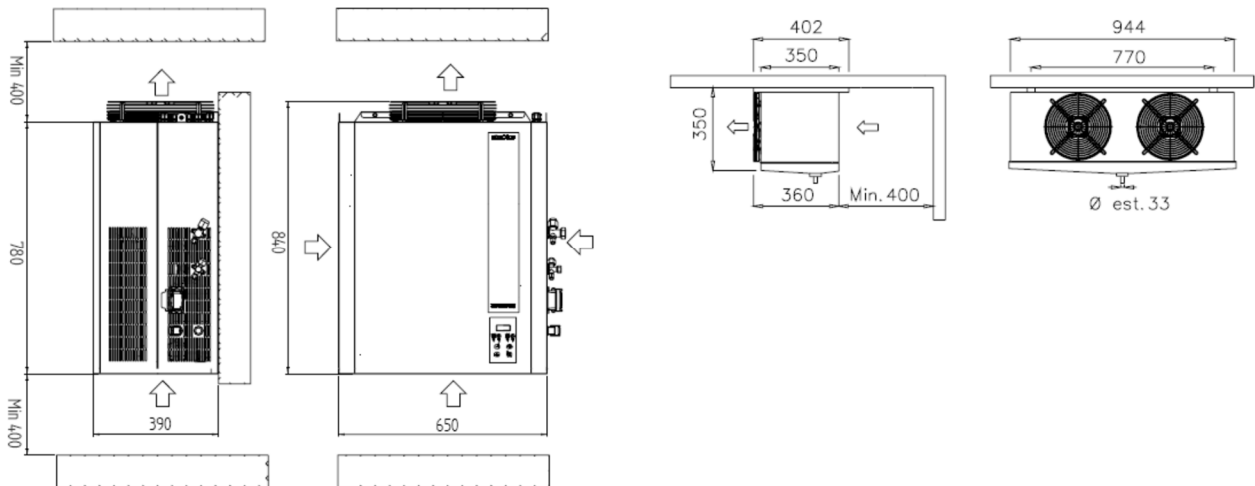

CELLBOX Split-Units (R452a) – Figures and Dimensions

FORM Bc Packaging dimensions WxLxH: 1435 x 600 x 1475 mm

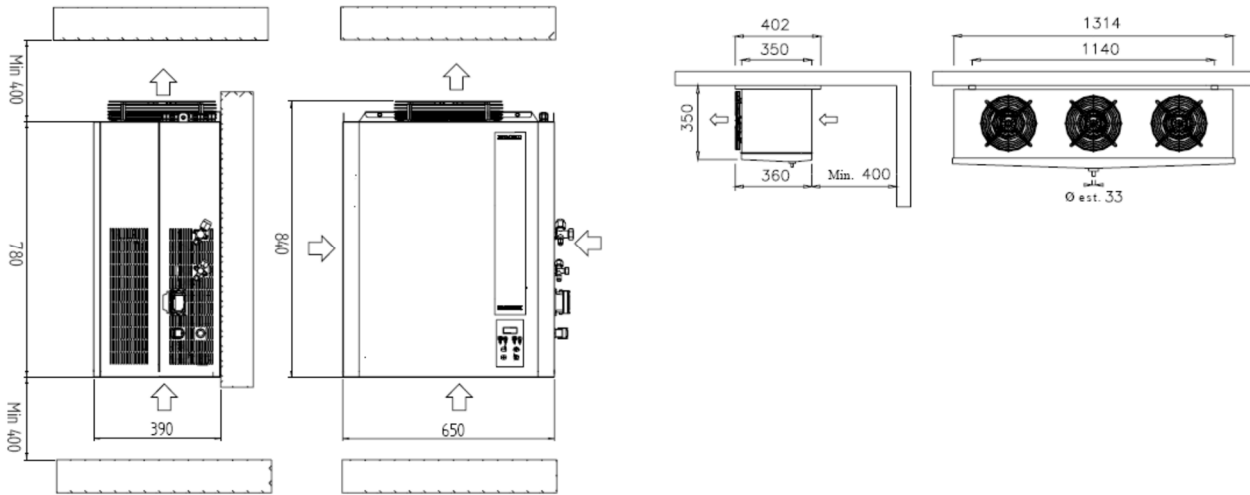

FORM C Packaging dimensions WxLxH: 1435 x 600 x 1475 mm

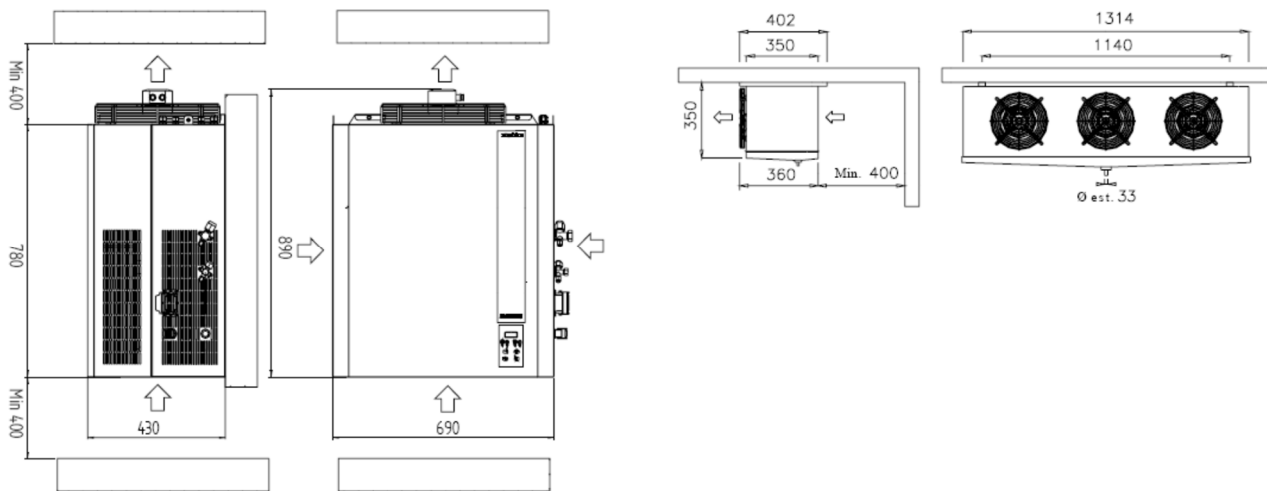

CELLTHERM provides a wide variety of shelving systems for coldrooms. Both compact and universally applicable, they are **exclusively adapted to the dimensions of CELLTHERM coldrooms**.

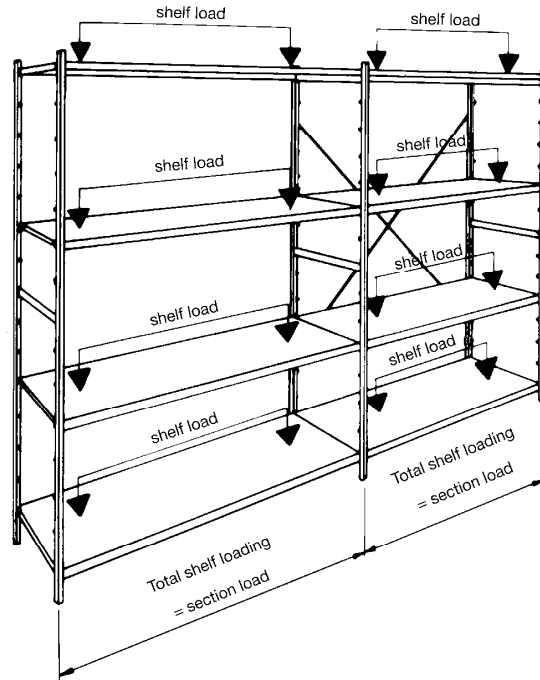

- Shelving frames manufactured from special 25 x 25 mm square pipes
- Feet can be adjusted by means of screwing, variable up to 20 mm in height
- Plastic grid shelves consisting of polystyrene can easily be removed for cleaning by means of a dishwasher.
- Optional: solid shelves consisting of 1.5 mm thick aluminium sheets beveled on both sides
- 90° corner arrangements can be assembled without a need for additional shelving frame
- Simple assembly by the customer

Shelving frames are available in the following heights: 160, 180, and 200cm for max. field load of 600kg.

For a shelving depth of 400 mm, the grid and solid shelves consisting of polystyrene exhibit a width of 600, 800, 900, 950, 1000, 1200, 1250, 1300, 1350, 1400, 1500mm.

For evenly distributed loads, the following load-bearing capacities apply:

Grid shelves:

600 – 1200 mm wide	150 kg
1250 -1500 mm wide	100 kg

Solid shelves:

600 – 1000 mm wide	150 kg
1200 – 1500 mm wide	100 kg

In cases of corner arrangements, the loads of the load-bearing shelves are reduced by approx. 30%.

Additional sizes as well as stainless steel shelving systems are available upon request!

Depending on the size of the coldroom, CELLTHERM offers a variety of standard shelving systems in L- or U-shape to facilitate the optimum utilization of our coldrooms (**PUR 80 and 120 mm**).

Each field of our ready-made shelving systems of type **1512** through type **2929** exhibit 3 grid shelves or 2 grid shelves underneath the vaporizer. These types are readily available from our warehouse.

Examples for installation:

Shelving system in L-shape

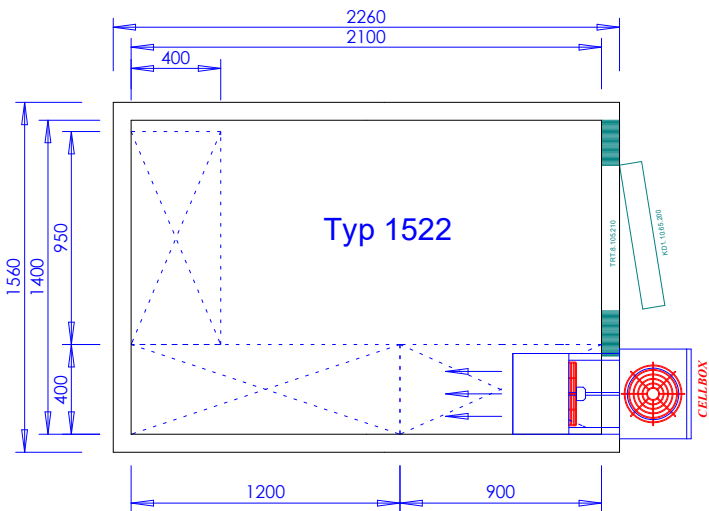

Shelving system in U-shape

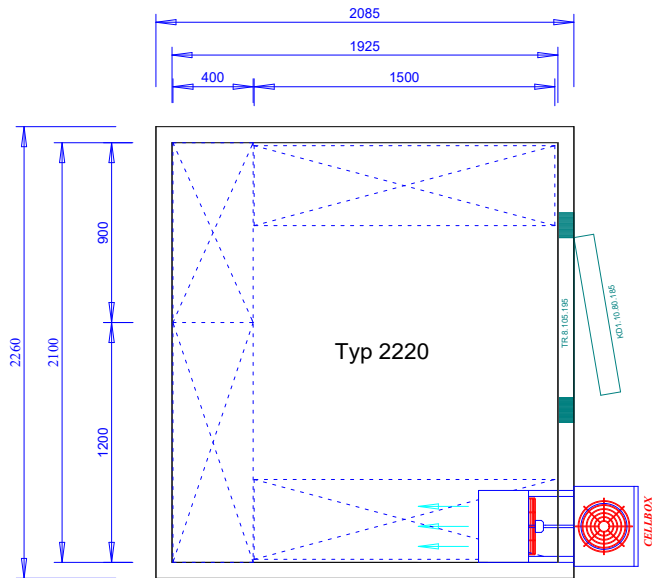

Individual elements:

Plastic grid shelf
polystyrene,
Carrier beams aluminium

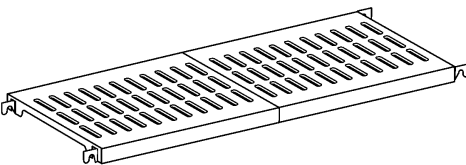

Shelving frames aluminium, with screwable feet
and plastic caps, height increments 150 mm,
max. field load 600kg.

Solid plastic shelf
polystyrene,
carrier beams aluminium

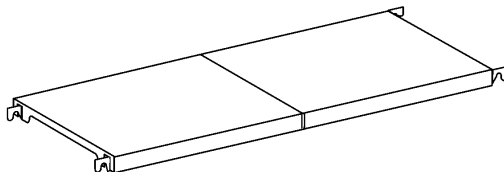

Cross support

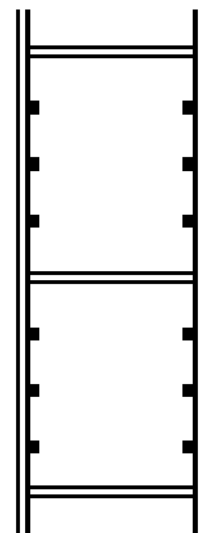
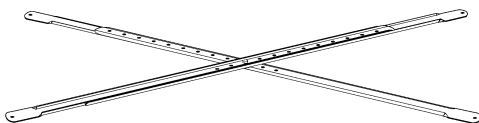

General Terms and Conditions of Sale, Delivery and Payment of CELLTHERM Isolierung GmbH

I. Scope of our terms and conditions

The contract is subject exclusively to our General Terms and Conditions of Business; we expressly contradict deviating purchasing terms and conditions of the customer. If the terms and conditions of the customer exclude a contradiction, then the statutory provisions take the place of contradicting terms and conditions.

II. Scope of deliveries

1. For the delivery scope, our written order confirmation is decisive, and the offer if we make an offer that is accepted in due time if no order confirmation is received in due time. Ancillary agreements and changes require our approval in writing.

2. Drawings, illustrations, dimensions, weights or other performance data are only binding if they are listed in our order confirmation or in the offer accepted in due time.

3. Unless we are obligated to assemble, unloading the goods from the transport vehicle is the concern of the customer.

III. Prices

1. Unless specially agreed otherwise, our prices are inclusive packaging and transporting the goods to the business domicile of the customer or to the place specified by him or to the dockside for deliveries to German islands or to the German border for deliveries abroad, as well as transport insurance in the usual scope.

2. The respective amount of statutory VAT is added to the prices.

3. Unless stated otherwise, we hold ourselves bound to the prices stated in our offer or order confirmation for 30 days as from their date.

4. In the case of contracts with an agreed delivery time of more than 4 months, we reserve the right to increase prices in accordance with increased wages or material prices. The customer has the right to cancel if the increase is more than 5% of the agreed price.

IV. Delivery time

1. Delivery dates or deadlines that can be bindingly or non-bindingly agreed must be set out in writing.

2. An agreed delivery deadline is fulfilled if the delivery item has left our factory or has been notified as ready for shipment by that time.

3. The delivery period prolongs appropriately in the case of measures concerning labour disputes, especially strikes and lockouts, and in the case of unforeseen hindrances outside our scope of influence if said hindrances probably have considerable influence on completion or shipment of the delivery item. This applies also if such circumstances come about at our sub-suppliers. We are also not answerable for the aforesaid circumstances if they arise during an already occurred default. In significant cases we will notify the beginning and end of such hindrances to the customer at the earliest possible time.

4. If shipment is delayed at the wish of the customer, then the costs for storage, at least 0.5% of the invoice amount per month of storage in our factory, starting from one month following notice of readiness for shipment will be charged to the customer. However, following the grant and fruitless expiry of a subsequent period, we are entitled to dispose over the delivery item otherwise and deliver to the customer with an appropriately longer delivery period.

5. Compliance with the delivery period presupposes that the contractual obligations of the customer are fulfilled.

6. If we are answerable for non-compliance with bindingly assured due periods and dates or if we are in default, the claim of the customer for default damage compensation is limited to one half percent for each week of default, but at most 5% of the invoice value of the deliveries and services affected by the default. Claims above and beyond this are excluded unless the default was caused by at least gross negligence on our part.

7. We are entitled to perform partial deliveries and services at all times.

8. We are entitled to demand compensation for the damage we incur if the customer is in default with acceptance; the risk of coincidental deterioration and coincidental destruction of the delivery item passes to the customer as soon as the acceptance default comes into being.

9. We are entitled to withdraw from the contract if the customer withdraws from the contract for reasons for which we are not answerable or if he does not accept our performance despite a set period to comply. If the ordered performance is a standard product, the damage compensation flat rate is 20% of the order value. The damage compensation flat rate for customized products is 70% of the order value.

V. Passage of risk

1. The risk passes to the customer at the latest with handover of the delivery items to the transport enterprise, and this even then if partial deliveries are made or if we have assumed other performances, e.g. shipment costs or export or assembly.

2. If shipment is delayed due to circumstances for which the customer is answerable, then risk passes to the customer as from readiness for shipment; however, we are obligated to arrange the insurance demanded by the customer at his wish and expense.

3. Notwithstanding his rights from Section VI, the customer must accept delivered items even then if they show insignificant defects.

4. The customer must evidence that a defect already existed prior to passage of risk. This does not apply in case of malicious deceit or wilful conduct or in the case of a defect that could not have been caused by interventions in the goods by the customer or third parties.

5. Inasmuch as we are also commissioned with assembly of the delivery item, we are entitled to demand a visual acceptance by the customer on the day the assembly is completed. Visible defects must be recorded in a protocol that must be signed by both parties. If no visual defects of the goods exist according to the protocol, then we have no liability whatsoever in this respect in future. The same applies if the customer does not fulfil the visual acceptance in due time. If defects are recorded in the protocol, we obligate ourselves to remedy them promptly.

VI. Liability for redhibitory defects

1. Obvious defects must be complained within one week as from receipt of the delivery item. Inasmuch as the customer is a merchant, unobvious defects must be complained within one week following their discovery. Complaints any later are excluded. Defects must be complained in writing. The defects must be described as precisely as possible.

2. If a defect falls within our scope of responsibility, we may at our own discretion deliver subsequent performance by remedying the defect or by substitute delivery in accordance with the statutory provisions. In the case of defect remedy, we are obligated to assume all expenditure, especially transport, travel, labour and material costs necessary to remedy the defect inasmuch as these do not increase due to the fact that the delivery item has been removed after delivery to a place other than the place of fulfilment or inasmuch as fittings by third parties must be removed or rebuilt.

3. Following consultation with us, the customer must accord us the time and opportunity to undertake all defect remedy measures or substitute deliveries that we at our own discretion deem necessary, otherwise we are released from liability for defects. Only in urgent cases of hazard to operating safety and to avert disproportionately high damages, whereby we must be informed immediately, or if we are in default with the remedy of a defect, does the customer have the right to remedy the defect himself or have it remedied by a third party and demand from us reimbursement of the costs necessarily incurred.

4. If the remedy of a defect fails after our third subsequent improvement attempt or if we are not prepared or unable to remedy the defect or make substitute delivery or if this is delayed beyond appropriate deadlines due to reasons for which we are answerable, then the customer is entitled to withdraw from the contract or demand a reduction of the purchase price.

5. Claims of the customer above and beyond this, especially damage compensation claims including lost profits or due to other economic losses, are excluded.

6. The foregoing liability limitation does not apply if the damage caused is founded in wilful conduct or gross negligence on our part or in cases of injury to life, limb or health.

7. Inasmuch as deviating agreements have not been made, the warranty period for liability for redhibitory defects is 12 months as from shipment of the delivery item. The same due period also applies to claims for compensation of consequential damages inasmuch as no claims are asserted on the grounds of unlawful conduct.

8. In the case of passing on our deliveries and performances within the framework of consumer goods sales, the customer is obligated to firstly immediately forward to us complaints and subsequent performance demands of the end-consumer for scrutiny and remedy before further rights of recourse can be asserted.

9. No warranty is given for damage caused by the customer himself due to unsuitable or improper use, erroneous assembly or taking into operation by the customer or third parties, erroneous or careless handling, damage to the lacquered surface and corrosion due to this, unsuitable operating resources, chemical or physical influences, failure to observe the assembly, operating and maintenance instructions by the customer or third parties, and due to effects of parts of third party origin and natural wear and tear (especially on parts subject to wear such as e.g. seals, door locks or hinges).

10. The provisions under Section VI., 2.-4. do not apply to delivery items used outside Germany. In such cases we give a 12-month material and parts guarantee. We do not assume other expenditure for the purpose of remedying defects, especially transport, travel and material costs.

VII. Reserve of proprietary rights

1. We reserve ownership of the delivered goods until receipt of all payments from the total liabilities arising from the business relationship. In the case of behaviour by the customer in breach of contract, we are entitled to recover possession of the delivered items. Recovery of possession or attachment of the conditional commodity does not constitute withdrawal from the contract.

2. The delivered goods may not be pledged or assigned as security without our approval. In cases of attachment or other access of third parties, the customer must inform us immediately in writing and accord us all assistance necessary to safeguard our rights.

3. The customer is entitled to resell or fit the delivery items subject to our reserved proprietary rights. For this case, the customer herewith assigns to us his purchase price claims against his buyer or his claim for remuneration for work against his principal to the amount of our claim. We herewith accept the assignment. We revocably empower the customer to collect the claims assigned to us in our name for our account. We are entitled to notify the assignment to the buyer or principal and to revoke the authorisation to collect as soon as the customer is in arrears with payment or an agreed partial payment. In this case, the customer is obligated on our demand to disclose to us the names and addresses of his buyers or his principal, as well as the data and scope of delivery agreements concluded with them.

4. We obligate ourselves to release the collateral to which we are entitled at the demand of the customer inasmuch as the value of our collateral is more than 20% above the value of the claims to be collateralised.

VIII. Payment

1. Our invoices are due for payment within 30 days of invoice date without deduction. Thereafter we are entitled to demand default interest of 8% over the respectively applicable basic interest rate. If we can evidence higher default damage, then we are entitled to assert this.

2. Despite terms of the customer worded otherwise, we are entitled to credit payments of the customer firstly against his older debts and will inform the customer of the type of netting undertaken. If costs and interest have already been incurred, then we are entitled to credit the payments firstly against the costs, then against the interest and finally against the main claim.

3. The customer is only entitled to a right of netting if his counterclaims are lawfully established, uncontested or acknowledged by us.

4. A payment is not considered as made before we can dispose over the amount. In the case of cheques, payment is not considered as made before the cheque is finally redeemed.

5. If we gain knowledge of circumstances that call the creditworthiness of the customer into question, especially if he does not redeem a cheque or discontinues his payments, then we are entitled to declare the entire remaining debt to be due, even if we have accepted cheques. In this case we are moreover entitled to demand that still pending deliveries are only made against advance payment or provision of collateral. We are entitled to withdraw after an appropriate subsequent period. Thereafter we can prohibit the resale of the goods delivered under the reserve of proprietary rights and demand that they be returned or that direct ownership be transferred at the expense of the customer.

IX. Liability limitation

1. We and our vicarious agents are only obligated to damage compensation due to breach of contract, culpa in contrahendo or from unlawful acts in the case of wilful conduct or gross negligence, unless life, limb or health are affected.

2. Any liability - also for lack of assured characteristics - is limited to the damage foreseeable at contract conclusion.

3. In every case our liability under product liability law and other claims from producer liability remain unaffected.

X. Place of fulfilment, place of jurisdiction, applicable law

1. Place of fulfilment is our registered place of business.

2. Place of jurisdiction for all contentions arising from and in connection with a delivery, also for cheque or bill of exchange claims, is the Local Court Gronau/Westphalia or the Regional Court Münster if the value in contention exceeds the competence of the Local Court.

3. Exclusively German law applies, also for deliveries outside Germany or for a foreign customer. The provisions of contract law of the United Nations Convention on Contracts for the International Sale of Goods (CISG) do not apply.

4. As from 1 June 2005, exclusively these General Terms and Conditions of Business shall apply for newly concluded contracts.

5. The invalidity of one of the foregoing provisions does not affect the validity of the other provisions. The corresponding statutory regulation shall apply in place of the invalid provision.