

CELLBOX wall-mount chiller (KW) and freezer (TW) units – Propane (R290)

The CELLBOX BLOCK SYSTEMS consist of a ready-to-use condensation unit, a vaporizer, and an electronic temperature controller. They provide a simple solution for various refrigeration applications. They are available in different designs and deliver reliability due to accurate selection of components, our most stringent production and quality controls, and our long-time experience in refrigeration.

GENERAL TECHNICAL CHARACTERISTICS

- **Natural coolant: R290 (Propane)**
- Filling volume coolant < 150 gr per refrigeration circuit (no extra safety measures required)
- High energy efficiency due to thermostatic expansion valves, pressure transmitters and EC-fans
- Extraordinarily environmentally-friendly: more than 40% less emissions compared to former units
- Electronic controller
 - Smart defrost and leak detector
 - Bluetooth connectivity
 - Remote control per App
 - LED display and backlit keyboard
- Hermetic compressors with thermal coil protection
- Air-cooled condensers with unprecedented low noise level
- Operating conditions: + 5 / + 43° C
- Self-supporting housing consisting of galvanised sheets, powder-coated
- CE approval
- Condensed water discharge directly into condensate evaporation bowl
- Heat exchanger with copper pipes and aluminium ribs

CELLBOX KW – Wall-Mount Units for Chilling – Propane

- 5 / + 5 °C

**Compact ready-to-use chilling unit for wall mounting
Piggyback devices, also available as slide-in devices upon request**

Coolant: R290 (Propane)

Standard equipment:

- Electronic controller (LED-display/keyboard; App)
- Switch ON / OFF and light switch
- Power cord 2.5 m with CEE-plug (16A/32A) - Fuse protection provided by customer
- Connection cable 2.5 m for door contact switch
- LED-lighting with 5 m cord
- Heated evaporation bowl for condensate
- High pressure switch
- For ambient temperature of up to 43°C

Refer to pages 6 – 7 for figures and dimensions

Type	CELLBOX KW100-R290 B			CELLBOX KW200-R290 B			CELLBOX KW300-R290 B			CELLBOX KW400-R290 B		
Form	A			A			B			B		
Electrical Parameters												
Voltage Volt/Ph/Hz	230 / 1 / 50			230 / 1 / 50			230 / 1 / 50			230 / 1 / 50		
Power consumption W	540			780			990			1200		
Current consumption A	2,9			4,3			5,4			6,5		
Electrical fuse protection	16A			16A			16A			16A		
Compressor												
Type	hermetic			hermetic			hermetic			hermetic		
Condenser												
Fan (diameter) mm	1 x 254			1 x 254			1 x 300			1 x 300		
Air quantity m ³ / h	600			600			1200			1200		
Vaporizer												
Fan (diameter) mm	1 x 200			1 x 200			2 x 200			2 x 200		
Air quantity m ³ / h	500			500			1000			1000		
Air dispersion m	6,5			6,5			6,5			6,5		
Expansion	Valve			Valve			Valve			Valve		
Type of defrosting	hot gas			hot gas			hot gas			hot gas		
Weight net / gross (kg)	45 / 58 kg			47 / 60 kg			64 / 89 kg			64,5 / 90 kg		
Noise level¹⁾ db(A)	31,6			31,4			35,5			36,5		
Cooling output W												
Coldroom temperature °C	+5	0	-5	+5	0	-5	+5	0	-5	+5	0	-5
At +32° C outside temp.	1073	938	812	1434	1256	1091	1840	1607	1390	2304	2023	1759
At +43° C outside temp.	955	832	719	1281	1123	975	1577	1373	1186	2054	1795	1554
Coldroom volume m³												
Coldroom temperature °C	+5	0	-5	+5	0	-5	+5	0	-5	+5	0	-5
At +32° C outside temp.	12,6	8,2	5,5	19,9	11,8	8,0	27,6	17,9	10,8	36,7	24,2	15,8
At +43° C outside temp.	6,6	4,5	3,1	9,6	6,6	4,6	13,2	8,6	6,0	21,0	12,4	8,5

All values based on 80mm PUR insulation thickness

Accessories:

- Water-cooled condenser
- Panel for slide-in device
- Cut-out for unit

1) Measured in 10 m distance; variations possible depending on ambient conditions.

CELLBOX KW – Wall-Mount Units for Chilling - Propane

- 5 / + 5 °C

**Compact ready-to-use chilling unit for wall mounting
Piggyback devices, also available as slide-in devices upon request**

Coolant: R290 (Propane)

Standard equipment:

- Electronic controller (LED-display/keyboard; App)
- Switch ON / OFF and light switch
- Power cord 2.5 m with CEE-plug (16A/32A) - Fuse protection provided by customer
- Connection cable 2.5 m for door contact switch
- LED-lighting with 5 m cord
- Heated evaporation bowl for condensate
- High pressure switch
- For ambient temperature of up to 43°C

Refer to page 8 for figures and dimensions

Type	CELLBOX KW500-R290 B			CELLBOX KW600-R290 B			CELLBOX KW700-R290 B			CELLBOX KW800-R290 B		
Form	C			C			C			C		
Electrical Parameters												
Voltage Volt/Ph/Hz	230 / 1 / 50			230 / 1 / 50			230 / 1 / 50			400 / 3 / 50		
Power consumption W	1490			1870			2000			2440		
Current consumption A	8,1			10,2			10,9			4,4		
Electrical fuse protection	16A			16A			16A			32A		
Compressor												
Type	hermetic			hermetic			hermetic			hermetic		
Condenser												
Fan (diameter) mm	1 x 300			1 x 350			1 x 350			1 x 350		
Air quantity m ³ / h	1200			2540			2540			2540		
Vaporizer												
Fan (diameter) mm	2 x 200			1 x 350			1 x 350			1 x 350		
Air quantity m ³ / h	1000			2740			2740			2740		
Air dispersion m	6,5			8			8			8		
Expansion	Valve			Valve			Valve			Valve		
Type of defrosting	hot gas			hot gas			hot gas			hot gas		
Weight net / gross (kg)	93 / 125 kg			102 / 134 kg			102 / 134 kg			103 / 135 kg		
Noise level¹⁾ db(A)	34,3			42,7			42,5			43,0		
Cooling output W												
Coldroom temperature °C	+5	0	-5	+5	0	-5	+5	0	-5	+5	0	-5
At +32° C outside temp.	2876	2521	2189	3537	3066	2630	3716	3245	2808	4435	3904	3405
At +43° C outside temp.	2574	2255	1956	3130	2691	2286	3199	2785	2406	3964	3473	3015
Coldroom volume m³												
Coldroom temperature °C	+5	0	-5	+5	0	-5	+5	0	-5	+5	0	-5
At +32° C outside temp.	48,4	32,2	21,6	62,3	41,2	27,5	66,1	44,2	30,0	81,6	55,5	38,3
At +43° C outside temp.	28,9	19,2	11,5	37,8	24,7	15,6	38,9	25,9	17,3	52,0	35,1	23,9

All values based on 80mm PUR insulation thickness

Accessories:

- Water-cooled condenser
- Panel for slide-in device
- Cut-out for unit

¹⁾ Measured in 10 m distance; variations possible depending on ambient conditions.

CELLBOX TW – Wall-Mount Units for Freezing - Propane

-15 / -25 °C

Compact ready-to-use chilling unit for wall mounting
Piggyback devices, also available as slide-in devices upon request

Coolant: **R290 (Propane)**

Standard equipment:

- Electronic controller (LED-display/keyboard; App)
- Switch ON / OFF and light switch
- Power cord 2.5 m with CEE-plug (16A/32A) - Fuse protection provided by customer
- Connection cable 2.5 m for door contact switch
- LED-lighting with 5 m cord
- Heated evaporation bowl for condensate
- High pressure switch
- For ambient temperature of up to 43°C

Refer to pages 6-7 for figures and dimensions

Type	CELLBOX TW100-R290 B			CELLBOX TW200-R290 B			CELLBOX TW300-R290 B		
Form	A			A			B		
Electrical Parameters									
Voltage Volt/Ph/Hz	230 / 1 / 50			230 / 1 / 50			230 / 1 / 50		
Power consumption W	690			910			940		
Current consumption A	3,8			5,0			5,1		
Electrical fuse protection	16A			16A			16A		
Compressor									
Type	hermetic			hermetic			hermetic		
Condenser									
Fan (diameter) mm	1 x 254			1 x 254			1 x 300		
Air quantity m³ / h	600			600			1200		
Vaporizer									
Fan (diameter) mm	1 x 200			1 x 200			2 x 200		
Air quantity m³ / h	500			500			1000		
Air dispersion m	6,5			6,5			6,5		
Expansion	Valve			Valve			Valve		
Type of defrosting	hot gas			hot gas			hot gas		
Weight net / gross (kg)	46 / 59 kg			54 / 67 kg			64 / 89 kg		
Noise level¹⁾ db(A)	31,3			32,8			32,8		
Cooling output W									
Coldroom temperature °C	-15	-20	-25	-15	-20	-25	-15	-20	-25
At +32° C outside temp.	782	663	554	1082	919	770	1263	1069	892
At +43° C outside temp.	695	588	491	959	810	675	1111	936	774
Coldroom volume m³									
Coldroom temperature °C	-15	-20	-25	-15	-20	-25	-15	-20	-25
At +32° C outside temp.	7,1	4,6	3,0	11,2	7,4	4,9	15,4	9,1	6,0
At +43° C outside temp.	3,9	2,6	1,7	6,2	4,2	2,8	7,6	5,1	3,4

All values based on 100mm PUR insulation thickness

Accessories:

- Water-cooled condenser
- Panel for slide-in device
- Cut-out for unit

¹⁾ Measured in 10 m distance; variations possible depending on ambient conditions.

CELLBOX TW – Wall-mount Units for Freezing - Propane

-15 / -25 °C

**Compact ready-to-use chilling unit for wall mounting
Piggyback devices, also available as slide-in devices upon request**

Coolant: R290 (Propane)

Standard equipment:

- Electronic controller (LED-display/keyboard; App)
- Switch ON / OFF and light switch
- Power cord 2.5 m with CEE-plug (16A/32A) - Fuse protection provided by customer
- Connection cable 2.5 m for door contact switch
- LED-lighting with 5 m cord
- Heated evaporation bowl for condensate
- High pressure switch
- For ambient temperature of up to 43°C

Refer to pages 7-8 for figures and dimensions

Type	CELLBOX TW400-R290 B	CELLBOX TW500-R290 B	CELLBOX TW600-R290 B	CELLBOX TW700-R290 B								
Form	B	B	C	C								
Electrical Parameters												
Voltage Volt/Ph/Hz	400 / 3 / 50	230 / 1 / 50	400 / 3 / 50	400 / 3 / 50								
Power consumption W	1180	1300	1800	2300								
Current consumption A	2,1	7,1	3,3	4,2								
Electrical fuse protection	32A	16A	32A	32A								
Compressor												
Type	hermetic	hermetic	hermetic	hermetic								
Condenser												
Fan (diameter) mm	1 x 300	1 x 300	1 x 350	1 x 350								
Air quantity m ³ / h	1200	1200	2540	2540								
Vaporizer												
Fan (diameter) mm	2 x 200	2 x 200	1 x 350	1 x 350								
Air quantity m ³ / h	1000	1000	2740	2740								
Air dispersion m	6,5	6,5	8	8								
Expansion	Valve	Valve	Valve	Valve								
Type of defrosting	hot gas	hot gas	hot gas	hot gas								
Weight net / gross (kg)	68 / 100 kg	93 / 125 kg	101 / 133 kg	110 / 138 kg								
Noise level¹⁾ db(A)	35,5	35,3	42,3	42,5								
Cooling output W												
Coldroom temperature °C	-15	-20	-25	-15	-20	-25	-15	-20	-25	-15	-20	-25
At +32° C outside temp.	1497	1274	1067	1824	1539	1283	2553	2161	1802	3030	2580	2161
At +43° C outside temp.	1309	1109	923	1584	1325	1091	2248	1893	1566	2654	2248	1871
Coldroom volume m³												
Coldroom temperature °C	-15	-20	-25	-15	-20	-25	-15	-20	-25	-15	-20	-25
At +32° C outside temp.	20,8	11,6	7,7	28,3	17,4	10,0	46,9	29,6	18,4	60,1	38,5	24,4
At +43° C outside temp.	9,6	6,5	4,4	13,2	8,4	5,6	25,8	15,7	9,2	33,5	21,4	11,9

All values based on 100mm PUR insulation thickness

Accessories:

- Water-cooled condenser
- Panel for slide-in device
- Cut-out for unit

¹⁾ Measured in 10 m distance; variations possible depending on ambient conditions.

CELLBOX Wall-mount units (R290) – Figures and Dimensions

FORM A

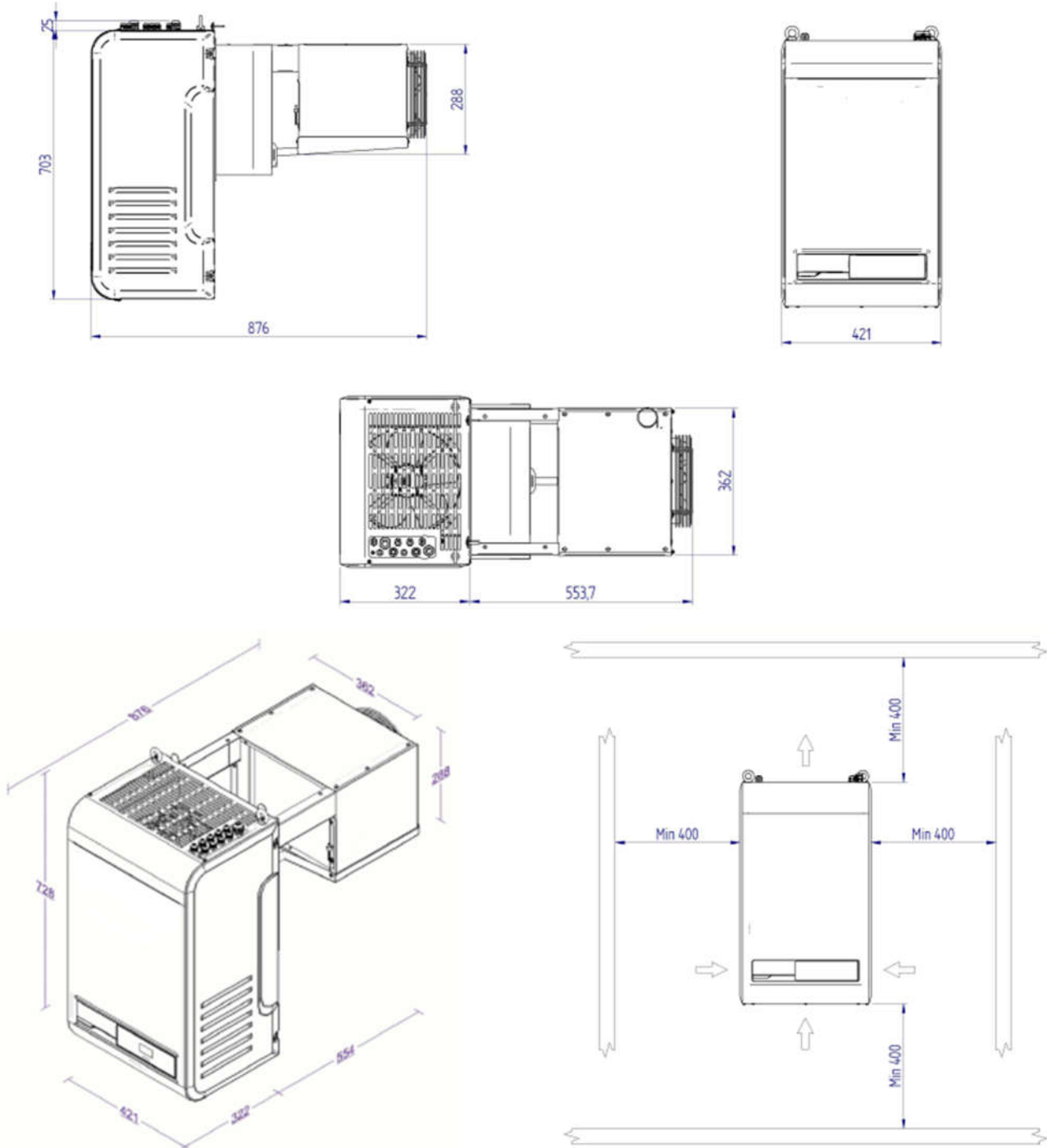

CELLBOX Wall-mount Units (R290) – Figures and Dimensions

FORM B

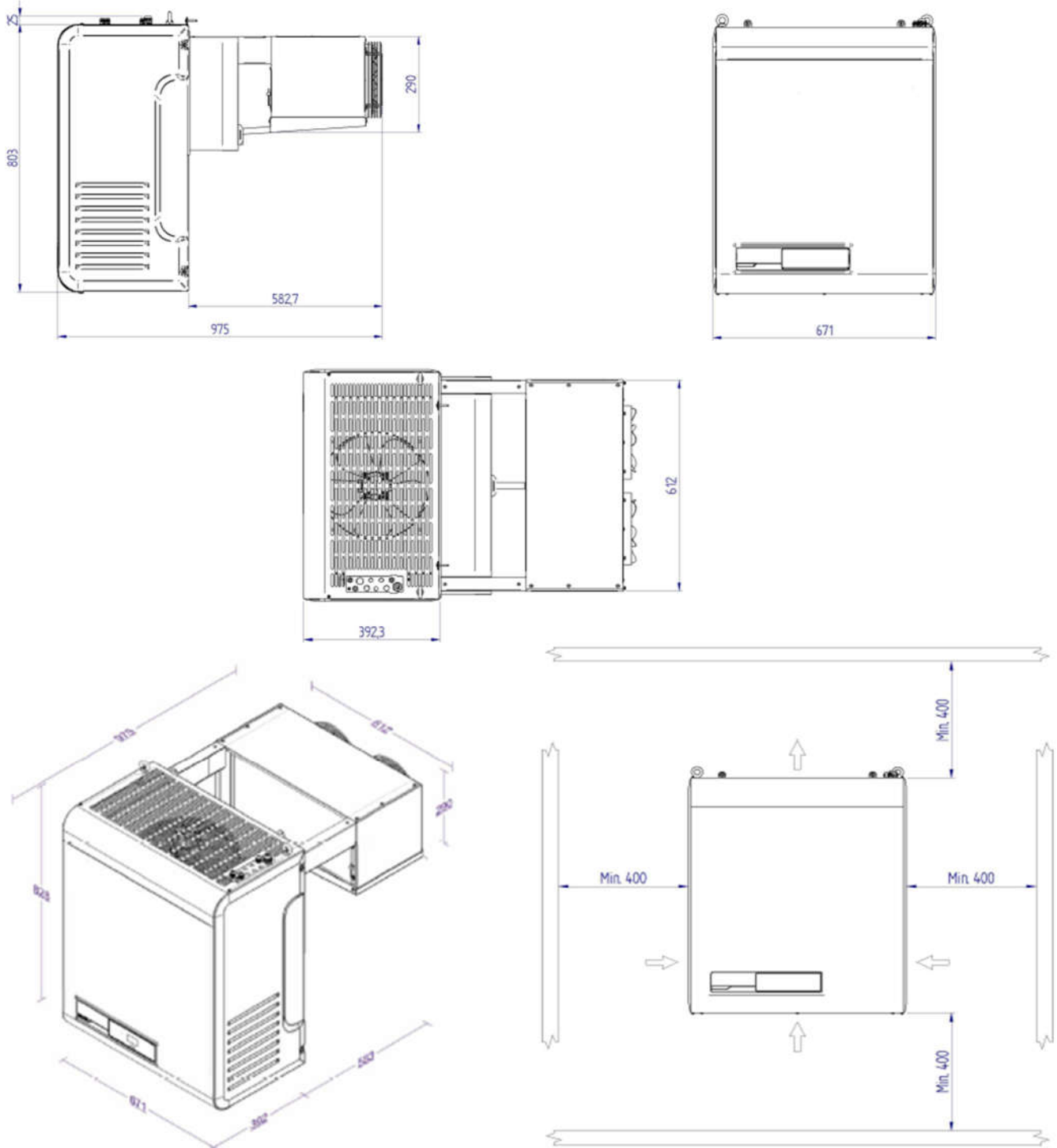

CELLBOX Wall-mount Units (R290) – Figures and Dimensions

FORM C

